

UDC 631.361.22

THE RESULTS OF THE STUDY OF THE CUTTER OF THE REMAINS OF ROOT CROPS HAULM

Volodymyr Boyko¹; Viktor Baranovsky¹; Vitalii Pankiv¹;
Volodymyr Onyshchenko²; Sergey Marinenko¹

¹*Ternopil Ivan Puluj National Technical University, Ternopil, Ukraine*

²*National University of Life and Environmental Sciences of Ukraine,
Kyiv, Ukraine*

Summary. Fodder beet pulp is harvested separately using the principle of cutting it at the root. The agrophysical characteristics of root crops (location of their heads relative to the soil surface) greatly affect the process of separating the remains of the pulp from the heads. At the same time, it is advisable to carry out the technological process of collecting scallions in a combined (two-stage) way. It combines the cutting of the main mass of the gorse and the subsequent removal of the remains of the gorse from the heads of root crops with cutters of the «passive copier-passive knife» type. The aim of the research is to increase the functional indicators of the gorse-harvesting modules by developing improved working bodies for cutting the gorse. The article provides a description of the technological process of the improved cutter for the remnants of hemlock and the results of comparative experimental studies of three designs of cutters.

Key words: fodder beets, haulm remnants, technological process, cutter of root crop heads, copier, sprung-loaded knife, polyfactorial experiment, empirical model, knocked out root crops.

https://doi.org/10.33108/visnyk_tntu2023.01.099

Received 30.01.2023

Statement of the problem. Reconstruction of the production potential of Ukraine in the post-war period is impossible without sustainable development of the agro-industrial complex. The livestock sector is an important link in ensuring the country's food security. In this context, fodder beet root crops are one of the types of juicy fodder for dairy cattle. Fodder beet pulp is one of the sources of renewal of soil fertility after it has been incorporated into the soil environment [1].

The problem of improving of haulm-cleaning modules technical level, cutting haulm quality indicators are their assessment criteria, remains particularly relevant in terms of further development of root crops technique [2].

Haulm harvesting is one of the most labor-intensive operations in the technological process of fodder beet production. Modern directions for the development of single-phase propelled root crops machines provide block-modular principle of their construction. Two-stage method of haulm harvesting is the first stage of single-phase technology of harvesting root crops – cutting the main body of haulm by rotary haulm cutter followed by cutting the remnants of haulm by a «passive copier-passive knife» re-cutter [3, 4, 5].

Since the first development and application of technical devices and facilities for mechanical harvesting of root crops extensive experience in the establishment of relevant working bodies and machines has been gained in the world practice. Agrobiological and mechanical properties of root crops and haulm of fodder beets, their location relative to the surface of the soil largely influence the work conditions modules of harvesting haulm. These indicators accordingly regulate construction features of working bodies for harvesting the main array of haulm and cutting off its remnant from root crops heads [6, 7, 8].

Reduction of root crops yield during the harvesting is caused by their losses during digging up and haulm harvesting. This is due to significant number of root crops knocked out from the soil (1.5...2.0%) and damaged root crops (15...20%), of these by chipping surface of heads cutting – up to 10%. At the same time the wastes of cutted root crops heads with haulm to the total mass are within 5...8%, and the pollution of root crops thresh by remnants of haulm amounts to 3...5% [9, 10, 11, 12, 13].

Obtained indicators of operating machines for haulm cleaning or their harvesting modules are unsatisfactory. They do not correspond to the established parameters in accordance with the agrotechnical requirements on the basis of their imperfection constructive and technical decisions the main working bodies – rotary haulm cutters and of haulm remnants re-cutters of root crops heads.

There are a lot of design and layout schemes for cutting and harvesting haulm and working bodies of beet harvesting machines: from haulm cutting rotors to fodder root re-cutters. This is related to both the harvesting technologies and agro-technical requirements for haulm cleaning and roots vegetables quality indicators [14, 15].

There are many ways of mechanical haulm removal of root crops such as cutting, beating down, tear off. Cutting and knocking down of haulm are the most common ones.

Based on the study of technological processes of cutting haulm and constructive-technological schemes of haulm harvesting modules and haulm harvesting machines of domestic and foreign production one can be stated the following. At present haulm-cutting devices typically cut haulm only on the principle "on the root". In such case main body haulm harvesting occurs without copying the heads of root crops and and haulm remnants cutting – with copying of root crops heads by differernt mechanisms [16, 17, 18, 19].

Therefore improvement of structural and layout schemes and working bodies of machines for haulm harvesting or haulm harvesting modules and substantiation parameters of their working bodies should be carried out taking into account the specific properties of this process. This is particularly important and actually in providing the necessary quality indicators of work according to the agrotechnical requirements [20, 21].

Statement of the problem. Objective of work is to increase technological process indicators of haulm harvesting of fodder beet root crops through the development and substantiation of working parameters of haulm harvesting machines.

Materials and methods. One of the ways to increase the efficiency of the technological process of harvesting root crops, which is a complex scientific and technical task, is the search for new structural schemes of working bodies and improved root harvesting modules created on their basis, which are component systems of modern self-propelled root harvesting machines, Fig. 1.

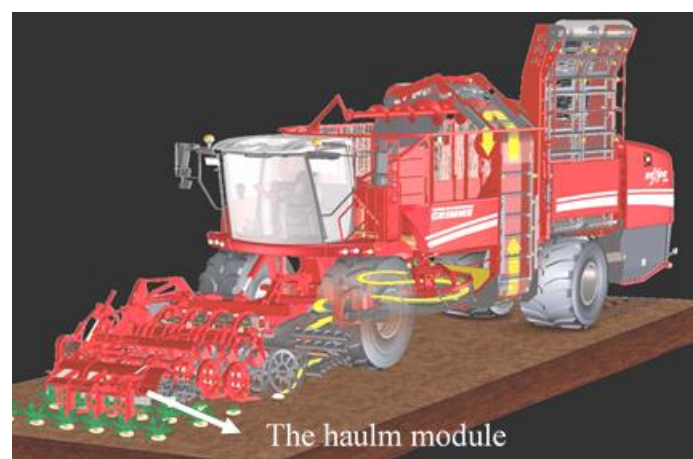

Figure 1. General diagram of a self-propelled bunker harvester

Mostly, the structural and layout schemes of self-propelled bunker harvesters and root harvesting machines of the world's leading companies are of the same type and have a similar structure, Fig. 1.

On the frame chassis, which rests on the support wheels, in front of the steered wheels of the machine, a chaff collecting module is attached to implement a two-stage method of chaff collection and a module for digging root crops, in the space between the bases of the chassis – a cleaning and transportation module dug pile of root crops and the module for accumulating cleaned root crops from impurities, which, as a rule, is made in the form of a hopper-accumulator of root crops and an unloading conveyor, and behind the hopper-accumulator – a power module, or an engine. The cabin with the machine's control bodies and working bodies is installed above the front steerable wheels of the machine [22].

Devices that carry out haulm cutting on the root by the cutting method are divided into machines for single-phase haulm cleaning method and machines for the two-phase method of haulm harvesting, which in turn are divided according to the type of job. Cutting, during which haulm cleaning is the result of knife blade cutting, is applied both for the bulk haulm harvesting and its remnants while cutting heads of root crops. And the knives, which can be active or passive, carry out haulm cutting without anti-cutting elements or counter movement of knives. Primarily it is caused by root crops properties, fodder beet haulm and harvesting or using haulm technology – using haulm for fodder or as an organic fertilizer by spreading it on a harvested field [23, 24]. At the same time, mechanized harvesting of a chicory root crop involves performing two consecutive and related technological operations or stages [25], they are cutting off the main array of the plant and trimming the remains of the branch from the heads of the roots crops [26].

Based on the study of technological processes that implement the cutting of the tops of root crops and technological schemes of haulm harvesters and technical means of domestic and foreign production [27], it can be stated that at the present stage, haulm harvesters cut the main mass of haulm only according to the principle «on the vine», which perform haulm harvesting without copying the heads of root crops [28]. Depending on the further use of the cut plant, there are two ways of harvesting the majority of the plant: loading the plant that has been cut by the disk working bodies (Fig. 2) or using it for animal feed; and spreading the plant which has been cut and chopped by rotary cutter knives on the surface of the field as siderates or fertilizers [29, 30].

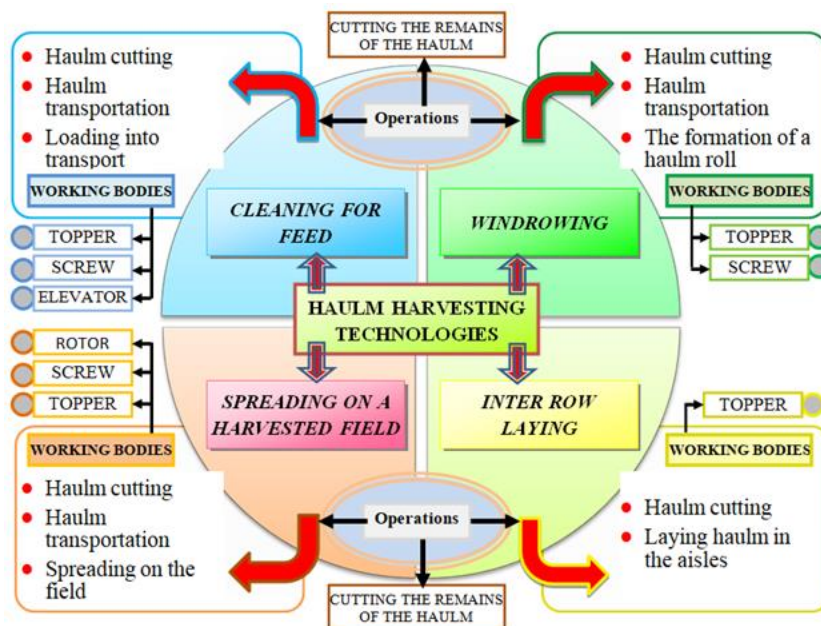

Figure 2. Scheme of the main operations for harvesting the tops of root crops

In connection with the significant increase in the price of energy resources, and in most cases of significant contamination of the biological structure of the leaves of haulm with herbicides and pesticides, the method of harvesting haulm for animal feed is not used. In this case, it is more effective to transplant the cut root crop into the soil environment [31, 32].

Based on the analysis of quality work indicators and technological parameters of haulm harvesting, we proposed an improved machine for haulm harvesting that is used according to the chosen haulm harvesting technology or method of haulm usage.

A well-known cutter for the remnants of root vegetables (Fig. 3), each of them is designed as a parallelogram hinged suspension. Passive comb copier 2 and knife 3 are mounted sequentially on the bracket 1 of parallelogram hinged suspension 1 [33, 34, 35].

Each knife 3 is designed as two-arm lever 5. The lever is installed at its finger 6 pivotally. The finger rigidly is fixed on a support 7, which is connected to the bracket 1 rigidly. Working stroke of the blade 4 of the cutting edge of the knife 3 in the horizontal plane is limited to support 8 which is mounted on the vertical finger 6 and support 9. The knife 3 is spring-loaded through a spring 10, one end of which is fixed on a two-arm lever 5, and the second – on the fixed support 7. Shock absorber blow is made in the form of gasket 12 of elastic material, or, for example, compression spring. It is installed between the bracket 1 parallelogram suspension and copier 2.

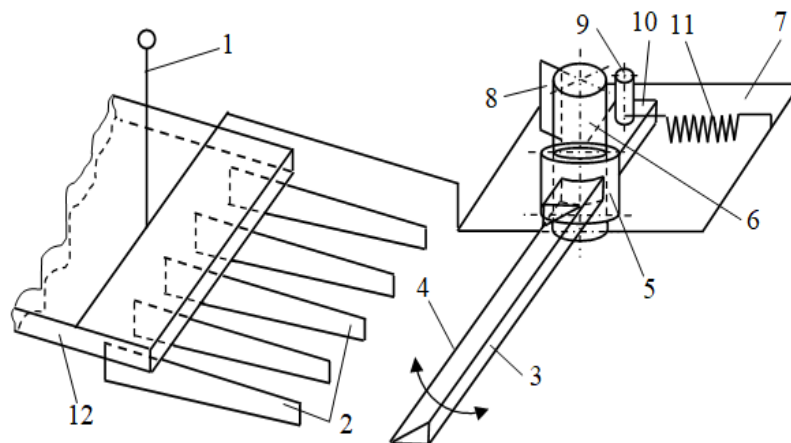

Figure 3. Construction diagram of the cutter of the remains of the haulm from the heads of root crops:
 1 – the riser; 2 – copier; 3 – knife; 4 – knife blade; 5 – two-arm lever; 6 – finger; 7 – fixed support;
 8 – support; 9 – stop; 10 – arm of lever; 11 – spring; 12 - shock absorber blow

However, due to the rigid connection of the copying parallelogram of the suspension, the proposed cutter damages a significant part of fodder beet root crops. Damage to root crops occurs due to significant dynamic loads that appear in the process of contact interaction between the copier and the head of root crops.

On the basis of the analysis of the obtained work quality indicators and the technological indicators of the beet pulp harvesting, we have proposed improved haulm of the fodder beet pulp residue cutter.

For more efficient elimination and damage to the root crops in the process of dynamic contact of the copier 2 (Fig. 3) with the root crop, we have proposed an improved design of the root crop of root crops, the use of which can significantly improve the quality of cutting of the residues of bush and the general indicators of the process of harvesting. To reduce the dynamic load on the body of the root crop, the design of the riser 1 was improved, which was associated with the parallelogram mechanism (Fig. 3 is not shown), copier 2 and knife 3.

The advanced construction of the riser, which is associated with a parallelogram mechanism and a copy of the outline of the remains of a bush from the heads of the root crops is shown in Fig. 4.

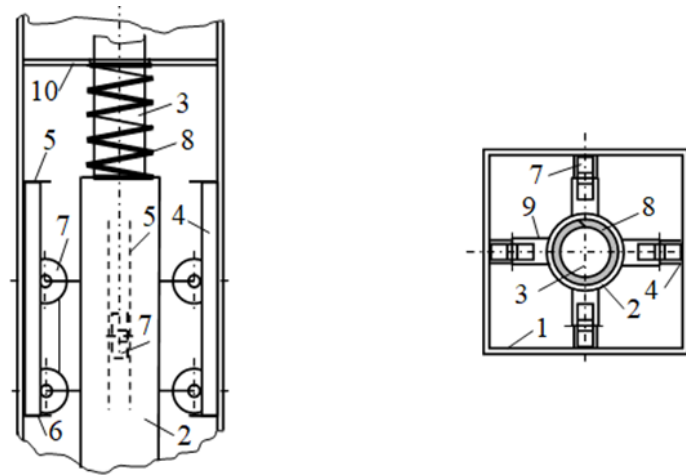

Figure 4. Generalized scheme of advanced riser of the outline of the remnants of the bush from the heads of the root crops: 1 – the riser; 2 – moving; 3 – finger; 4 – the side restrictive; 5, 6 – the restraint, respectively, upper and lower; 7 – roller; 8 – compression spring; 9 – a roller bracket; 10 – supporting plate

Inside the riser 1 (Fig. 4) is mounted by moving thrust 2, which at the top goes into finger 3. The lower part of the moving thrust is fixed to the plate copier 2 (Fig. 3), which is rigidly bound to the cut with a knife 3. To the lateral surface of the moving traction 2 (Fig. 4), the bracket 9 is fixed rollers 7, which move up and down into their grooves formed by restrictive sides 4. The movement of moving rollers is limited by the upper 5 and lower 6 limiters, which are made in the form of flat plates. The compression spring is inserted into the finger 3, the upper part of which rests on the thumbnail 10.

In the process of work, part of the dynamic load resulting from the contact interaction of the copier 2 (Fig. 3) with the head of the root crop is transmitted through moving thrust 2 (Fig. 4) and compensated (spent) for compression of the spring 8, which reduces components (horizontal and normal tangent) forces of pressure on the root.

Additionally, due to the shock absorber blow that is made in the form of gasket 12 (Fig. 3) impact force of copier is significantly reduced. A part of the impact energy is spent on the deformation of the shock absorber or compensated for deformation gaskets and it reduces beating out from the soil or damage of root crops.

To determine use efficiency of improved re-cutter construction mounted on the machine field comparative experimental studies of three types cutters: a standard cutter of root crops heads (firms «Kleine», «Moreau», «Tim» etc., version 1), cutter of root crops heads which has a spring-loaded knife and copier is installed on shock absorber in the form of an elastic plate (version 2) and an advanced specimen of the remains of a haulm from the heads of root crops, a riser 1 of which was made according to Fig. 4 (version 3).

Variable factors of two-factor experiment were accepted: machine speed; root crops height relatively to the soil level. The results of coding and levels of variation of factors are shown in the table 1 below.

Table 1

Results of coding of factors and their levels of variation

Factors	The interval of variation		Levels of variation, (Natural/Coding)	
	Working speed of the module V_M , m/s	0,3	1,2/-1	1,5/0
The height of placement of root crops in relation to soil level h_r , cm	3	3/-1	6/0	9/+1

Results and discussion. After processing the numerical values of the general sample (sample volume – 100 root crops of fodder beets), regression equations were obtained, which characterize the functional dependence of the change in the optimization parameter on the progressive speed V_M of the boggy modulus of the location of the location h_r of the codes of root crops relative to the surface of the soil:

- the number of fodder beet-boiled root crops from soil B_{ir} from the total number of root crops of one sample

$$\left. \begin{aligned} B_{1r} &= -13,7 + 17,1V_M - 4,4h_r + 1,7V_M h_r - 3,1V_M^2 + 0,3h_r^2; \\ B_{2r} &= 20,8 - 14,6V_M - 5,8h_r + 0,8V_M h_r + 5,2V_M^2 + 0,5h_r^2; \\ B_{3r} &= 11,2 - 9,2V_M - 4,4h_r + 0,4V_M h_r + 4,2V_M^2 + 0,5h_r^2 \end{aligned} \right\}; \quad (1)$$

- the number of damaged root crops of fodder beet Π_{ir} from the total number of root crops of one sample

$$\left. \begin{aligned} \Pi_{1r} &= -19,9 + 38,3V_M - 13,2h_r + 3,8V_M h_r - 10,4V_M^2 + 1,0h_r^2; \\ \Pi_{2r} &= 7,9 + 12,9V_M - 13,6h_r + 4,2V_M h_r - 5,2V_M^2 + 0,8h_r^2; \\ \Pi_{3r} &= 65,6 - 39,8V_M - 15,8h_r + 3,8V_M h_r + 7,3V_M^2 + 1,0h_r^2 \end{aligned} \right\}. \quad (2)$$

According to the regression equations (1)–(2), a graphic integration of functional changes in optimization parameters in the ode of the response surface: the number of fodder beet – boiled root crops from soil B_{ir} from the total number of root crops of one sample, Fig. 5, Fig. 6; the number of damaged root crops of fodder beet Π_{ir} from the total number of root crops of one sample, Fig. 7, Fig. 8.

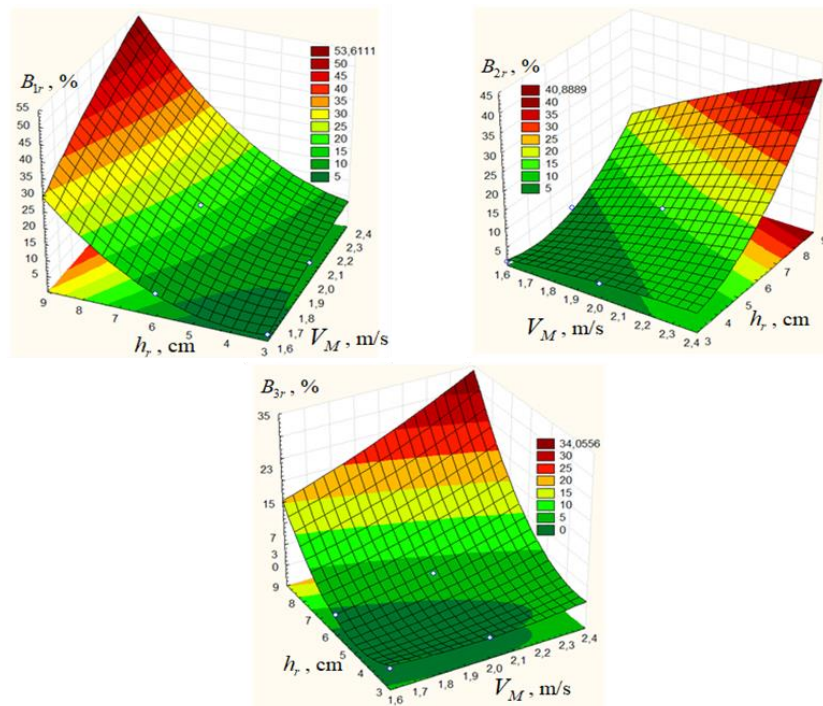

Figure 5. The response surface of the number of root of root crops from the soil as punks $B_{ir} = f_B(V_M, h_r)$

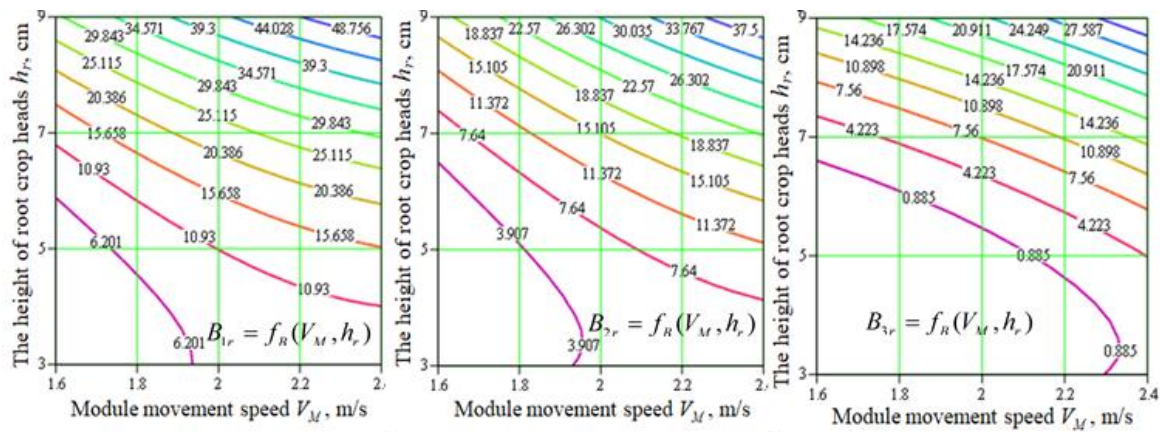

Figure 6. Two-dimensional section of the response surface as a function of $B_{ir} = f_B(V_M, h_r)$

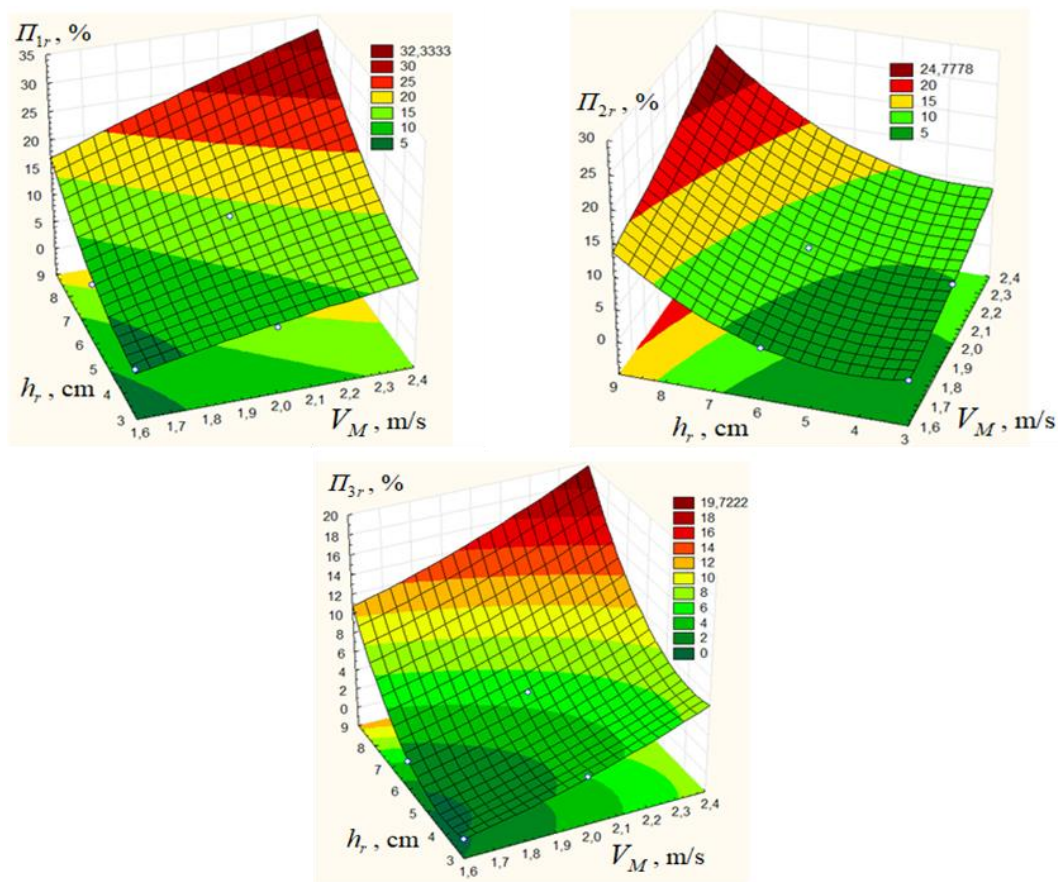

Figure 7. The response surface of the amount of damaged root crops as punks $\Pi_{ir} = f_{\Pi}(V_M, h_r)$

Based on the analysis of regression equations (1) and response surfaces (Fig. 5, Fig. 6) established that the character of change in the number of knocked out root crops from the soil B_{ir} , for of three types cutters constructions is the same. With increasing speed of the machine V_M and root crops height h_r relatively to the soil level, values of B_{ir} increase as a percentage of root crops (B_{1r}, B_{2r}, B_{3r} , Fig. 5, Fig. 6). Moreover the largest number of knocked out root crops from the soil, as a percentage of root crops B_{ik} is observed in standard cutter, whose values are in the range of $B_{1r} = 5...53\%$. Accordingly, the minimum values of number of knocked out root crops from the soil $B_{3r} = 4...34\%$ is inherent for cutter, in which knife is made spring-loaded and copier rigidly is fixed on the shock absorber which is designed as an elastic plate.

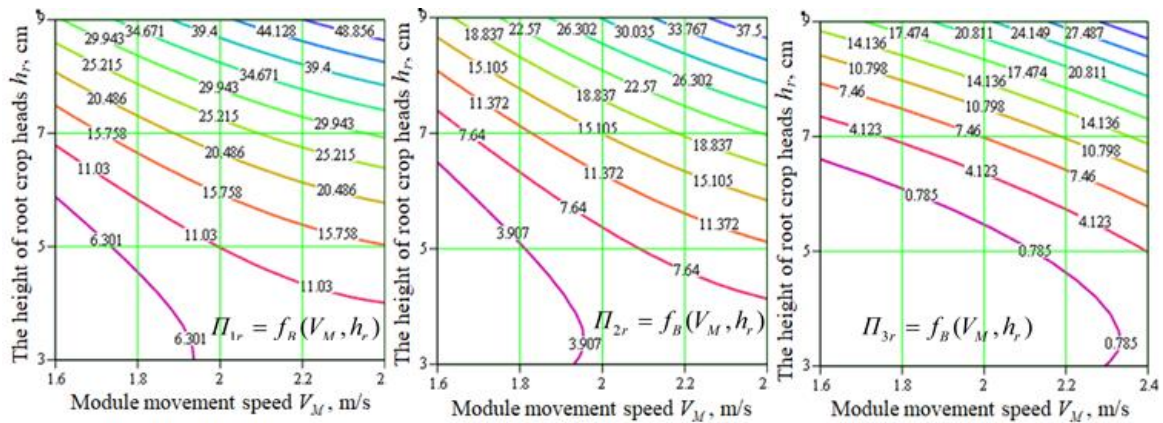

Figure 8. Two-dimensional section of the response surface as a function of $\Pi_{ir} = f_B(V_M, h_r)$

The significant decrease in the number of root crops knocked out from the soil B_{3r} relatively B_{1r} is reached by replacing rigid processes of cutting haulm on the process of cutting by method of sliding the blade cutting edge of spring-loaded knife and partial compensation of the horizontal component of knocked out root crops through shock absorber.

The height of placement of heads root crops in relation to soil level is the dominant factor, which influence on parameter optimization indicators or the number of knocked out roots h_r from the soil (Fig. 5, Fig. 6).

Within the limits of increasing this factors from 3 to 9 cm the number of root crops knocked out from the soil by working bodies of all types cutter are increasing: B_{ir} – on average in 6 times.

Based on the analysis of the constructed response surfaces and their two-dimensional sections (Fig. 7, Fig. 8), it was established that the nature of the change in the number of damaged root crops Π_{1r} , Π_{2r} , Π_{3r} for the three types of construction design of the trimmer is similar – with an increase in the speed of movement of the picker module V_M and the height of the location h_r of root crops relative to the soil surface level, Π_{ir} values increase.

At the same time, the largest number of damaged root crops Π_{ir} , k, as a percentage of the number of root crops, is observed in the serial pruner, the values of which are in the range of $\Pi_{1r} = 5...32\%$.

Accordingly, the minimum values of the number of damaged root crops $\Pi_{3r} = 0...19\%$ were obtained for the pruner, in which the knife is spring-loaded, and the copier is rigidly installed on the shock absorber, which is made in the form of an elastic gasket.

A significant reduction in the number of damaged root crops Π_{3r} relative to Π_{1r} is achieved by replacing the rigid process of "cutting down" the stalks of the gorse with a cutting process by sliding the blade of the cutting edge of the spring-loaded trimmer knife and partially compensating the horizontal component of the contact force of the root crops with a shock absorber.

The dominant factor that affects the indicator of the optimization parameter or the number of damaged root crops is the height of the root crop heads relative to the soil level h_r (Fig. 7, Fig. 8).

Within the limits of the increase in the height of the roots above the soil surface from 3 to 9 cm, the number of damaged roots by the working bodies of all three types of execution of the cutting knife and the copier of the cutter of the picker module increases Π_{ir} on average by 6...8 times.

Conclusions. Thus, improved design of haulm remnants re-cutter of root crops of fodder beet consists of re-cutter, which is designed as a passive copier and is mounted on shock absorbers and of spring-loaded knife. Using this design is allowed to intensify the process of removing haulm remnants, while the number of root crops knocked out from the soil is reduced by about 1.5 ... 2.0 times.

References

1. Dubrovin V., Golub G., Baranovskii V., Teslyuk V. Identifikatsiya protsessa razrobotki adaptirovannoi korneuborochnii mashini. MOTROL. Commission of motorization and energetics in agriculture. An international journal on operation of farm and agri-food industry machinery. 2013. Vol. 15. No. 3. P. 243–255.
2. Klimuk M. V., Herasymchuk O. O., Podoliak V. M. Ohliad mashyn dlia vydalennia hychky z holovok koreneplodiv tsukrovkykh buriakiv. Naukovi notatky. 2002. Vyp. 11. P. 182–186. <https://doi.org/10.1080/714005354>
3. Berezhenko E. Experimental research of the module for gathering plant of chicory roots. Scientific Journal of the Ternopil National Technical University. 2021. Vol. 1 (101). P. 56–67. https://doi.org/10.33108/visnyk_tntu2021.01.056
4. Pogorelii L. V., Tatyanko M. V. Svekluborochnie mashini: istoriya, konstruktsiya, teoriya, prognoz. K.: Feniks, 2004. 232 p.
5. Mou X. Kinematic analysis and experiments of elastic dentations in process of sugarcane leaf sheath stripping. Agricultural Mechanics Report. Journal of Shandong Agricultural University. 2014. Vol. 2. P. 122–1294.
6. Baranovsky V. M., Potapenko M. V. Theoretical analysis of the technological feed of lifted root crops. INMATEH: Agricultural Engineering. 2017. Vol. 51. No. 1. 2017. P. 29–38.
7. Herasymchuk H. A. et al. Analytical research results of the combined root digger. INMATEH – Agricultural Engineering. 2018. Vol. 54. No. 1. 2018. P. 63–73.
8. Jobbagy J., Gabaj D., Arvay J. Evaluation of selected agro-physical properties of a root vegetable. Acta Technologica Agriculturae. 2011. Vol. 14. No. 3. P. 61–65.
9. Hevko R. B. et al. Development of design and investigation of operation processes of small-sclale root crop and potato harvesters. INMATEH-Agricultural Engineering. 2016. Vol. 49. No. 2. P. 53–60.
10. Hevko R et al. Advances in methods of cleaning root crops. Bulletin of the Transilvania University of Brasov, Series II. 2018. Vol. 11 (60). No. 1. P. 127–138.
11. Smal M. V., Herasymchuk O. O., Baranovskiy V. M. Matematychni modeli protsesu kopiiuvannia holovok koreneplodiv kopirom pasyvnoho doobrizchkyka zalyshkiv hychky. Zb. nauk. prats Vinnytskoho natsion. ahrar. un-tu. Serii: Tekhnichni nauky. 2012. Vyp. 11. T. 1 (65). P. 206–212.
12. Smal Mariia, Herasymchuk Oleh. Konstruktyvno-tekhnologichnyi analiz obrizuvachiv holovok koreneplodiv tsukrovkykh buriakiv. Innovatsion texnologiyar. Qarshi muchandislik-igtisodivot istituti: Qarchi, 2014. No. 2 (14). P. 29–36. <https://doi.org/10.1007/s15027-014-0438-2>
13. Martynenko V. Ia. Hychkozbyralni mashyny. Ternopil: TOV “Polihrafist”, 1997. 108 p.
14. Klimuk M. Obhruntuvannia parametriv rotornoho hychkozrizuvalnoho aparatu. Visnyk Ternopilskoho derzhavnoho tekhnichnoho universytetu. 2003. T. 8. No. 3. P. 64–68.
15. Rybak T. et al. Analytical and applied model of the process of the cut vegetable components feeding to the screw conveyor of the top gathering module. Scientific Journal of TNTU. 2018. Vol. 2 (90). P. 105–114. https://doi.org/10.33108/visnyk_tntu2018.02.105
16. Storozhuk I. M., Pankiv V. R. Research results of harvesting haulm remnants of root crops. INMATEH: Agricultural Engineering. 2015. Vol. 46. No. 2. P. 101–108.
17. Zbigniew B. Modelling And Numerical Analysis of Assembly System. Acta Mechanica et Automatica 2015. Vol. 9. No. 4. P. 145–150. <https://doi.org/10.1515/ama-2015-0024>
18. Tson A. et al. Feasibility study of an auger conveyor performance of the haulm removing module. Scientific Journal of TNTU. 2018. Vol. 3 (91). P. 101–106. https://doi.org/10.33108/visnyk_tntu2018.03.101
19. Onyshchenko V. B., Tesliuk V. V., Storozhuk I. M. ta in. Napriamky vdoskonalennia tekhnologichnoho protsesu vydalennia zalyshkiv hychky z holovok koreneplodiv. Mizhvid. temat. nauk. zb. Mekhanizatsiia ta elektryfikatsiia silskoho hospodarstva. XIV mizhn. nauk.-tekhn. konf. “Suchasni problemy zemlerobskoi mekhaniky”, prysviachena pamiati akad. P. M. Vasylenka. Hlevakha, 2013. P. 207–213.
20. Tson Anna et al. Experimental researches of parameters technological process of the improved beets tops purifier. Scientific Journal of TNTU. 2018. Vol. 4 (92). P. 60–67. https://doi.org/10.33108/visnyk_tntu2018.04.060
21. Pohorilyi L. V. Suchasni problemy zemlerobskoi mekhaniky i mashynoznavstva pry stvorenni silskohospodarskoi tekhniky novoho pokolinnia. Mekhanizatsiia silskohospodarskoho vyrobnytstva. 2003. Vyp. 20. P. 10–28.

22. Khelemendik N. M. Issledovanie tekhnologicheskogo protsessa i rabochikh organov dlya uborki sakharnoi svekli v usloviyakh Zapadnoi stepi USSR : avtoref. dis. na soiskanie uch. stepeni kand. tekhn. nauk : spets. 05.20.11 "Mekhanizatsiya selskokhozyaistvennogo proizvodstva". Voronezh, 1968. 18 p.
23. Smal M. V. Obhruntuvannia parametriv doobrizchyka zalyshkiv hychky. Zhurnal "Naukovyi ohliad". 2014. No. 2 (3). I chast. P. 163–172.
24. DSTU 4327:2004. Koreneplody kormovykh buriakiv dlia promyslovoho pererobliannia. Tekhnichni umovy (61776). Kyiv, 2004. 34 p.
25. Smal M. V. Eksperymentalni doslidzhennia zbyrannia hychky koreneplodiv. Naukovyi visnyk Natsionalnoho universytetu bioresursiv i pryrodokorystuvannia Ukrainy. 2014. No. 196. P. 323–330.
26. Pankiv M. Modeling of the technological functioning process transport and cleaning system of roots. Innovative solutions in modern science. 2019. Vol. 9 (36). P. 50–60.
27. Baranovsky V. et al. Results of the experimental investigations of fodder beets harvesting technologies. Scientific journal of TNTU. 2022. Vol. 105. No. 2. P. 6–16. https://doi.org/10.33108/visnyk_tntu2022.02.016
28. Kravchuk V. I., Hrytsyshyn M. I., Koval S. M. Suchasni tendentsii rozvytku silskohospodarskoi tekhniki. K.: Ahrarna nauka, 2004. 353 p.
29. Špokas L. et al. The experimental research of combine harvesters. Research in Agriculture Engineering 2016. Vol. 62. No. 3. P. 106–112. Doi: <https://doi.org/10.17221/16/2015-RAE>. <https://doi.org/10.17221/16/2015-RAE>
30. Martinov V. M. Sovremennie tekhnologii i mashini dlya uborki korneplodov: mirovoi obzor. Pratsi Tavriiskogo derzhavnogo agrotekhnologichnogo universitetu. 2011. Vip. 11. T. 5. P. 70–78.
31. Berezovyi M. H. Obgruntuvannia tekhnolohichnykh i konstruktyvnykh parametriv robochykh orhaniv mashyny dlia zbyrannia hychky tsukrovoho buriaku : avtoref. dys. na zdobuttia nauk. stupenia kand. tekhn. nauk: spets. 05.20.11 "Mashyny i zasoby mekhanizatsiia silskohospodarskoho vyrobnytstva". K.: NAU, 2007. 19 p.
32. Baranovskiy V. M., Storozhuk I. M., Tesliuk V. V., Onyshchenko V. B., Pankiv M. R. Hychkozrizivalna mashyna: patent na korysnu model № 101407 Ukraina, MPK A01D 23/02. Zaiavka № u201503283 ; zaiavl. 07.04.2015; opubl. 10.09.2015. Biul. № 17/2015.
33. Baranovskiy V. M., Storozhuk I. M., Tesliuk V. V., Onyshchenko V. B., Pankiv M. R. Hychkozrizivalna mashyna: patent na korysnu model № 102232 Ukraina, MPK A01D 23/02. Zaiavka № u201503891; zaiavl. 23.04.2015; opubl. 26.10.2015. Biul. № 20/2015.
34. Baranovskiy V. M., Pankiv V. R., Pylypets M. I., Pankiv M. R., Danylchenko L. M. Hychkozrizivalna mashyna: patent na korysnu model № 108588 Ukraina, MPK A01D 23/02. Zaiavka № u201600150; zaiavl. 05.01.2016; opubl. 25.07.2016. Biul. № 14/2016.
35. Smal Mariia. Doslidzhennia roboty rotornoho hychkoriza. Fundamental and Applied Studies in EU and CIS Countries: The 1 st International Academic Conference (United Kingdom, Oxford, 23 July 2014). Oxford. V. I "Oxford IADCES Press", 2014. P. 14–21.

Список використаних джерел

1. Dubrovin V., Golub G., Baranovskii V., Teslyuk V. Identifikatsiya protsessa razrabotki adaptirovannoi korneuborochnii mashini. MOTROL. Commission of motorization and energetics in agriculture. An international journal on operation of farm and agri-food industry machinery. 2013. Vol. 15. No. 3. P. 243–255.
2. Клімук М. В., Герасимчук О. О., Подоляк В. М. Огляд машин для видалення гички з головок коренеплодів цукрових буряків. Наукові нотатки. 2002. Вип. 11. С. 182–186. <https://doi.org/10.1080/714005354>
3. Berezhenko E. Experimental research of the module for gathering plant of chicory roots. Scientific Journal of the Ternopil National Technical University. 2021. Vol. 1 (101). P. 56–67. https://doi.org/10.33108/visnyk_tntu2021.01.056
4. Погорельий Л. В., Татьяна М. В. Свеклоуборочные машины: история, конструкция, теория, прогноз. К.: Феникс, 2004. 232 с.
5. Mou X. Kinematic analysis and experiments of elastic dentations in process of sugarcane leaf sheath stripping. Agricultural Mechanics Report. Journal of Shandong Agricultural University. 2014. Vol. 2. P. 122–1294.
6. Baranovsky V. M., Potapenko M. V. Theoretical analysis of the technological feed of lifted root crops. INMATEH: Agricultural Engineering. 2017. Vol. 51. No. 1. 2017. P. 29–38.
7. Herasymchuk H. A. et al. Analytical research results of the combined root digger. INMATEH – Agricultural Engineering. 2018. Vol. 54. No. 1. 2018. P. 63–73.
8. Jobbagy J., Gabaj D., Arvay J. Evaluation of selected agro-physical properties of a root vegetable. Acta Technologica Agriculturae. 2011. Vol. 14. No. 3. P. 61–65.
9. Hevko R. B. et al. Development of design and investigation of operation processes of small-sclale root crop and potato harvesters. INMATEH-Agricultural Engineering. 2016. Vol. 49. No. 2. P. 53–60.

10. Nevko R et al. Advances in methods of cleaning root crops. Bulletin of the Transilvania University of Brasov, Series II. 2018. Vol. 11 (60). No. 1. P. 127–138.
11. Смаль М.В., Герасимчук О.О., Барановський В.М. Математичні моделі процесу копіювання головок коренеплодів копиром пасивного дообрізчика залишків гички. Зб. наук. праць Вінницького націон. аграр. ун-ту. Серія: Технічні науки. 2012. Вип. 11. Т. 1 (65). С 206–212.
12. Smal Mariia, Herasymchuk Oleh. Konstruktyvno-tehnolohichniy analiz obrizuvachiv holovok koreneplodiv tsukrovoykh buriakiv. Innovatsionniy tehnologiyar. Qarshi muchandislik-igtisodivot instituti: Qarchi, 2014. No. 2 (14). P. 29–36. <https://doi.org/10.1007/s15027-014-0438-2>
13. Мартиненко В. Я. Гичкозбиральні машини. Тернопіль: ТОВ «Поліграфіст», 1997. 108 с.
14. Клімук М. Обґрунтування параметрів роторного гичкозрізувального апарату. Вісник Тернопільського державного технічного університету. 2003. Т. 8. № 3. С 64–68.
15. Rybak T. et al. Analytical and applied model of the process of the cut vegetable components feeding to the screw conveyor of the top gathering module. Scientific Journal of TNTU. 2018. Vol. 2 (90). P. 105–114. https://doi.org/10.33108/visnyk_tntu2018.02.105
16. Storozhuk I. M., Pankiv V. R. Research results of harvesting haulm remnants of root crops. INMATEH: Agricultural Engineering. 2015. Vol. 46. No. 2. P. 101–108.
17. Zbigniew B. Modelling And Numerical Analysis of Assembly System. Acta Mechanica et Automatica 2015. Vol. 9. No. 4. P. 145–150. <https://doi.org/10.1515/ama-2015-0024>
18. Tson A. et al. Feasibility study of an auger conveyor performance of the haulm removing module. Scientific Journal of TNTU. 2018. Vol. 3 (91). P. 101–106. https://doi.org/10.33108/visnyk_tntu2018.03.101
19. Онищенко В. Б., Теслюк В. В., Сторожук І. М. та ін. Напрямки вдосконалення технологічного процесу видалення залишків гички з головок коренеплодів. Міжвід. темат. наук. зб. Механізація та електрифікація сільського господарства: XIV міжн. наук.-техн. конф. «Сучасні проблеми землеробської механіки», присвячена пам'яті акад. П. М. Василенка. Глеваха, 2013. С. 207–213.
20. Tson Anna et al. Experimental researches of parameters technological process of the improved beets tops purifier. Scientific Journal of TNTU. 2018. Vol. 4 (92). P. 60–67. https://doi.org/10.33108/visnyk_tntu2018.04.060
21. Погорілий Л. В. Сучасні проблеми землеробської механіки і машинознавства при створенні сільськогосподарської техніки нового покоління. Механізація сільськогосподарського виробництва. 2003. Вип. 20. С. 10–28.
22. Хелемендик Н. М. Исследование технологического процесса и рабочих органов для уборки сахарной свеклы в условиях Западной степи УССР: автореф. дис. ... канд. техн. наук: спец. 05.20.11 «Механизация сельскохозяйственного производства». Воронеж, 1968. 18 с.
23. Смаль М. В. Обґрунтування параметрів дообрізчика залишків гички. Журнал «Науковий огляд». 2014. № 2 (3). I част. С. 163–172.
24. ДСТУ 4327:2004. Коренеплоди кормових буряків для промислового переробляння. Технічні умови (61776). Київ, 2004. 34 с.
25. Смаль М. В. Експериментальні дослідження збирання гички коренеплодів. Науковий вісник Національного університету біоресурсів і природокористування України. 2014. № 196. С. 323–330.
26. Pankiv M. Modeling of the technological functioning process transport and cleaning system of roots. Innovative solutions in modern science. 2019. Vol. 9 (36). P. 50–60.
27. Baranovsky V. et al. Results of the experimental investigations of fodder beets harvesting technologies. Scientific journal of TNTU. 2022. Vol. 105. No. 2. P. 6–16. https://doi.org/10.33108/visnyk_tntu2022.02.016
28. Кравчук В. І., Грицишин М. І., Коваль С. М. Сучасні тенденції розвитку сільськогосподарської техніки. К.: Аграрна наука, 2004. 353 с.
29. Špokas L. et al. The experimental research of combine harvesters. Research in Agriculture Engineering 2016. Vol. 62. No. 3. P. 106–112. Doi: <https://doi.org/10.17221/16/2015-RAE>. <https://doi.org/10.17221/16/2015-RAE>
30. Мартынов В. М. Современные технологии и машины для уборки корнеплодов: мировой обзор. Праці Таврійського державного агротехнологічного університету. 2011. Вип. 11. Т. 5. С. 70–78.
31. Березовий М. Г. Обґрунтування технологічних і конструктивних параметрів робочих органів машини для збирання гички цукрового буряку : автореф. дис. ... канд. техн. наук: спец. 05.20.11 «Машини і засоби механізація сільськогосподарського виробництва». К.: НАУ, 2007. 19 с.
32. Гичкозрізувальна машина: патент на корисну модель № 101407 Україна, МПК А01D 23/02. Заявка № u201503283; заявл. 07.04.2015; опубл. 10.09.2015. Бюл. № 17/2015.
33. Гичкозрізувальна машина: патент на корисну модель № 102232 Україна, МПК А01D 23/02. Заявка № u201503891; заявл. 23.04.2015 ; опубл. 26.10.2015. Бюл. № 20/2015.
34. Гичкозрізувальна машина: патент на корисну модель № 108588 Україна, МПК А01D 23/02. Заявка № u201600150; заявл. 05.01.2016; опубл. 25.07.2016. Бюл. № 14/2016.
35. Smal Mariia. Doslidzhennia roboty rotornoho hychkoriza. Fundamental and Applied Studies in EU and CIS Countries: The 1 st International Academic Conference (United Kingdom, Oxford, 23 July 2014). Oxford. V. I “Oxford IADCES Press”, 2014. P. 14–21.

УДК 631.361.2

РЕЗУЛЬТАТИ ДОСЛІДЖЕННЯ ЗРІЗУВАННЯ ЗАЛИШКІВ ГИЧКИ КОРЕНЕПЛОДІВ

Володимир Бойко¹; Віктор Барановський¹; Віталій Паньків¹;
Володимир Онищенко²; Сергій Мариненко¹

¹Тернопільський національний технічний університет імені Івана Пулюя,
Тернопіль, Україна

²Національний університет біоресурсів і природокористування України,
Київ, Україна

Резюме. У всесвітній практиці гичку кормових буряків збирають машинами роздільного збирання, використовуючи принцип зрізування гички на корені. Найбільш розповсюджений спосіб – роздільний, під час якого використовуються універсальні машини для збирання гички як кормових, так і цукрових буряків. Загальні властивості гички та коренеплодів, розміщення їх головок відносно поверхні ґрунту тощо значною мірою впливають на процес відокремлення залишків. Враховуючи специфічні механіко-технологічні властивості зв'язку гички з коренеплодами, можна зробити висновок, що технологічний процес збирання гички доцільно здійснювати комбінованим (двостадійним) способом, який містить зрізування основного масиву гички з наступним видаленням залишків гички на головках коренеплодів обрізниками типу «пасивний копір-пасивний ніж». Метою досліджень є підвищення функціональних показників роботи гичкозбиральних машин шляхом розроблення удосконалених робочих органів для зрізування гички. Наведено опис технологічного процесу роботи удосконаленого обрізника залишків гички з головок коренеплодів і результати порівняльних експериментальних досліджень трьох конструкцій обрізників. При цьому найбільша кількість вибитих коренеплодів з ґрунту від кількості коренеплодів спостерігається у серійного обрізника, значення якого знаходяться у діапазоні 5...53%. Відповідно, мінімальні значення кількості вибитих коренеплодів 4...34% відповідають удосконаленому обрізнику, в якого ніж виконаний підпружиненим, а копір жорстко встановлено на амортизаторі.

Ключові слова: кормові буряки, залишки гички, технологічний процес, обрізник головок коренеплодів, копір, підпружинений ніж, багатofакторний експеримент, емпірична модель, вибиті коренеплоди.

https://doi.org/10.33108/visnyk_tntu2023.01.099

Отримано 30.01.2023