

UDC 624.014

PECULIARITIES OF STUDYING THE STRESS-STRAIN STATE OF STRUCTURAL STEEL PERFORATED BEAMS USING THE FINITE ELEMENT METHOD

**Mykola Pidgurskyi; Ivan Pidgurskyi; Mykola Stashkiv;
Viktoriia Ihnatieva; Svitlana Danylchynko; Denys Bykiv; Oleh Pidluzhnyi**

Ternopil Ivan Puluj National Technical University, Ternopil, Ukraine

Summary. *The advantages and disadvantages of perforated beams are analyzed, the areas of their application during construction and reconstruction of buildings and structures are given. A comparative assessment of the stress-strain state of cellular beams using a modified mesh of elements was carried out using the finite element method in the specialized software packages ANSYS, SolidWorks, LIRA.*

Key words: *cellular beams, stress-strain state, finite element method, modified finite element mesh.*

https://doi.org/10.33108/visnyk_tntu2023.03.126

Received 10.06.2023

Problem statement. Perforated steel beams are a type of lightweight metal structure with through-thickness holes in the web. The holes are located along the entire beam and can have various shapes: circular, square, polygonal, oval, sinusoidal, and others [1, 3].

Steel beams with perforated web are an important structural element in construction and building renovation. These structures are primarily used in the construction of shopping centers, multi-story parking garages, stadiums, and spacious industrial premises [4]. They can also be used as crane beams in manufacturing facilities.

Perforated beams allow for spanning significant spans of 36–42 meters, which is several times larger than modern rolled I-beams. While having the same load-bearing capacity, perforated web beams provide 20–30% metal savings compared to rolled beams. Additionally, they are 10–18% cheaper. Another advantage of perforated beams is their better aesthetic appearance compared to other metal beams. These holes can be given a unique appearance for each individual structure, enhancing interior design [4].

Analysis of the available investigation outcomes. An overview of the structural solutions for perforated beams used in construction indicates a wide variety of shapes and locations of openings in the beam web [1–3, 5]. To choose the most rational perforation options for beams, it is necessary to conduct a study of their stress-strain state. In the construction industry, beams with hexagonal perforations are the most commonly used. The calculation of the stress-strain state and stability of such beams is regulated by normative documents [1, 6, 7]; for beams with circular holes [1, 6]. For selecting optimal structural solutions for other types of perforated beams (with oval, elliptical, sinusoidal, and other types of holes), any clear requirements are not available, so it is necessary to conduct research on the stress-strain state and stability for each type of hole.

Obtaining precise analytical relationships for assessing the stress-strain state of perforated beams is complicated by the peculiarities of how the web with openings behaves. In particular, some complex methods have been developed to predict the deflection of perforated beams [8, 9]. However, for most cases of calculating the deflections of perforated beams, some approximate formulas are used, which take into account the additional deflection of the beams caused by the deformation around the holes. In particular, in [1], the deflection (f) for beams

with hexagonal or circular holes is recommended to be determined using 90% of the net-section moment of inertia I_{x-net} , considering it as a prismatic section:

$$f = \frac{5ql^4}{384EI_{x-net} \cdot (0.90)},$$

where q – uniformly distributed load;
 l – span.

In analogy with the BS5950 standard [6], the influence of additional deflection due to the flexibility of the perforated web beams is assessed using a coefficient $K_s = 1.25$, which increases the deflection by 25%.

Additionally, for modeling such types of problems, numerical methods are used, including the finite element method (FEM), which allows for accurate prediction of the stress-strain state of perforated beams with various types of openings using modern specialized software packages such as ANSYS, ABAQUS, MSC/NASTRAN, and others [9–11].

For example, in the article [10], the influence of the size of finite elements in models of beams with circular openings was investigated and compared with experimental data [12]. Perforated beams with a length of 8.2 meters were examined under a concentrated force of 60 kN applied at the center of the beam. The beams had a height of 463.2 mm, a hole diameter of 325 mm, and the total number of holes was 20. Models with different finite element mesh sizes were studied: 100 mm, 50 mm, 25 mm, and 10 mm. It was demonstrated that the FE mesh size significantly affects the deflection magnitude. It is suggested to create models with a FE mesh size within the range of 25 mm to 10 mm, which shows good convergence with experimental data [12]. The finite element size in the models in the studies [9–11, 13] ranged from 25 mm to 30 mm.

Reducing the size of finite elements (FE) from 6 mm to 2 mm [14] allowed for a refinement of stress by 31.2%. However, this reduction in finite elements size had little effect on the deflection values of the beam.

It is worth noting that modeling the stress-strain state of perforated beams is most commonly performed in the ANSYS program. For instance, in [15], a comparison was made between the deflection calculations of a perforated beam with circular openings, according to the BS 5950 standard [6] and those performed in the ANSYS program. The calculation was conducted for a perforated beam with a length of 10 meters under the influence of a uniformly distributed load of 12.39 kN/m. The additional deflection due to the flexibility of the perforated web beams in [6] is assessed using a coefficient $K_s = 1.25$, which increases the deflection by 25%. The results obtained by the two methods differed by 5.2%. The size of the finite element in these studies ranged from 20 to 30 mm.

Modeling of perforated beams and the study of their stress-strain state were also carried out using the LIRA software package [13]. The size of the finite element was 25 mm in these mentioned studies.

The issue of creating a high-quality and, at the same time, rational finite element mesh is crucial when solving problems related to the strength and stiffness of perforated beams. The challenges in creating such a mesh are influenced by two factors: the large dimensions of the beams and the presence of a significant number of structural stress concentrators such as holes in the beam web, which have different shapes. On one hand, the FE mesh size for large-sized beams should be maximized to reduce the computational time of the model. On the other hand, it should be minimized to evaluate stress concentration factors in the regions of the holes. Specifically, these sizes should be significantly smaller than the technological radii of fillets, for example, at the vertices of hexagonal or octagonal holes. The impact of the finite element size on stress values, deflections, and the resulting errors is discussed in the article [14].

Therefore, the size reducing of finite elements when modeling beams with large spans is limited by the computer hardware's available memory. One approach to assess the stress concentration factors around openings is to create a local mesh with small elements around these openings and combine it with the global finite element mesh [5]. Reliable results can be obtained with a well-developed methodology for modeling experiments. It is also important to compare the research results obtained using different specialized software packages.

Hence, the **aim** of this work is to develop a methodology for assessing the stress-strain state of perforated beams using the finite element method and to verify the research results obtained using various specialized software programs.

Main body. To solve the set tasks, it is necessary to develop a research methodology. The most common method for investigating the stress-strain state of perforated beams is the finite element method. At the initial stage, a finite element model was created. To calculate the stress-strain state, the software packages LIRA-SAPR [18], SolidWorks [16], and ANSYS [17] were used.

Another important task is to determine the minimum size of the finite element to obtain reliable results while minimizing the calculation time.

The study of the stress-strain state was carried out on a steel perforated beam with circular holes. The length of the beam was taken as 4 meters to save time on modeling and calculation. The beam is hinge-supported with a point load in the middle, $P = 2 \text{ kN}$ (Fig. 1).

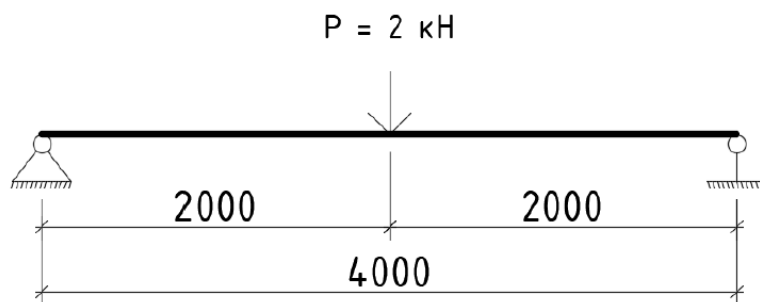

Figure 1. Calculation model of a freely supported perforated beam

The height of the cross-section of the finished perforated beam is 400 mm, the width is 100 mm, and the thickness of the flanges and web are 3 mm and 4 mm, respectively. The perforation diameter is 266.8 mm, and the hole spacing is 400.2 mm (Fig. 2).

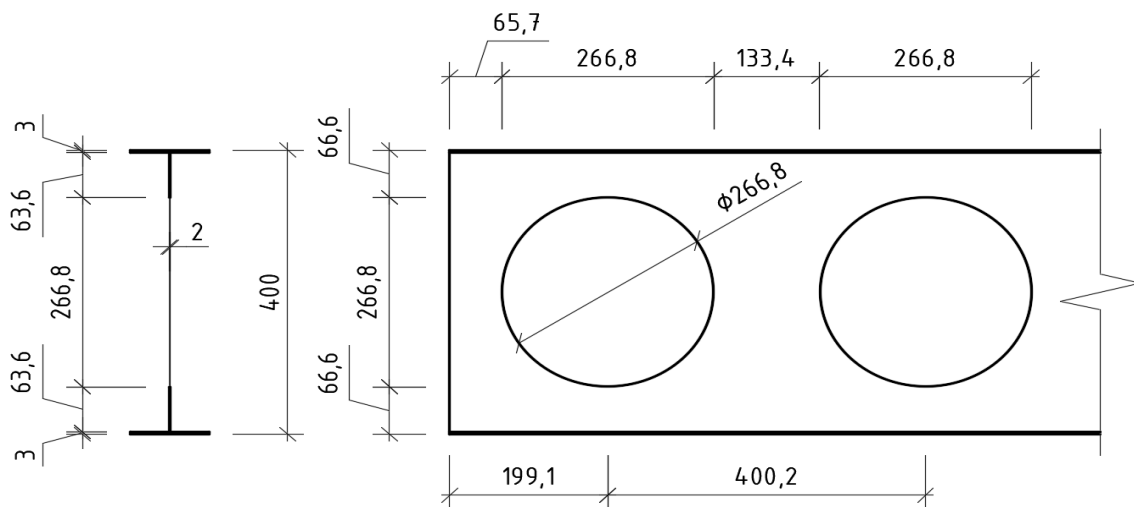

Figure 2. Geometric characteristics of the researched cellular beam

For the modeling, low-alloy steel of grade 09Г2С with a strength class of C345 was selected, with the following characteristics: elastic modulus $E = 210$ GPa; Poisson's ratio $\nu = 0.3$; yield strength $\sigma_T = 345$ MPa; ultimate strength $\sigma_B = 480$ MPa.

In each software package, two calculation models were chosen: in the first one, the average size of finite elements is 20 mm without densification at the edges of the perforation holes; in the second one, the average size of finite elements is 20 mm with densification at the edges of the perforation holes up to 2 mm.

The deflection of the beam was determined as its displacement along the vertical axis Z. Equivalent stresses were obtained using the energy theory of von Mises.

The study of the stress-strain state of the steel perforated beam was conducted using the LIRA software package. We have created a calculation model in LIRA based on the drawings 1 and 2. We have defined the relevant characteristics of steel and the boundary conditions as mentioned earlier. We have performed a complete calculation of the finite element models and obtained results for deflection (Figure 3) and equivalent stresses in the beam (Figure 4). Additionally, we have labeled the holes (see Figure 4) and determined the stresses for the outermost hole (No. 1) (Figure 5) and the one in the middle of the beam (No. 5) (Fig. 6).

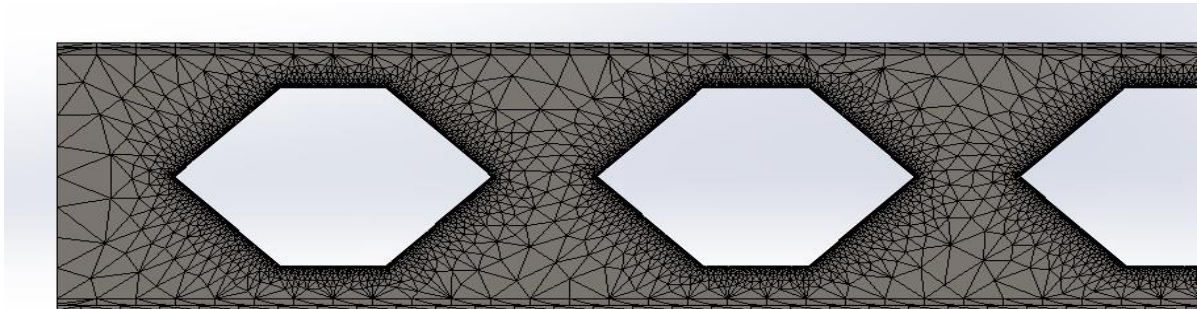

Figure 3. Assessment of the deflection of a perforated beam without mesh thickening of finite elements, mm (LIRA)

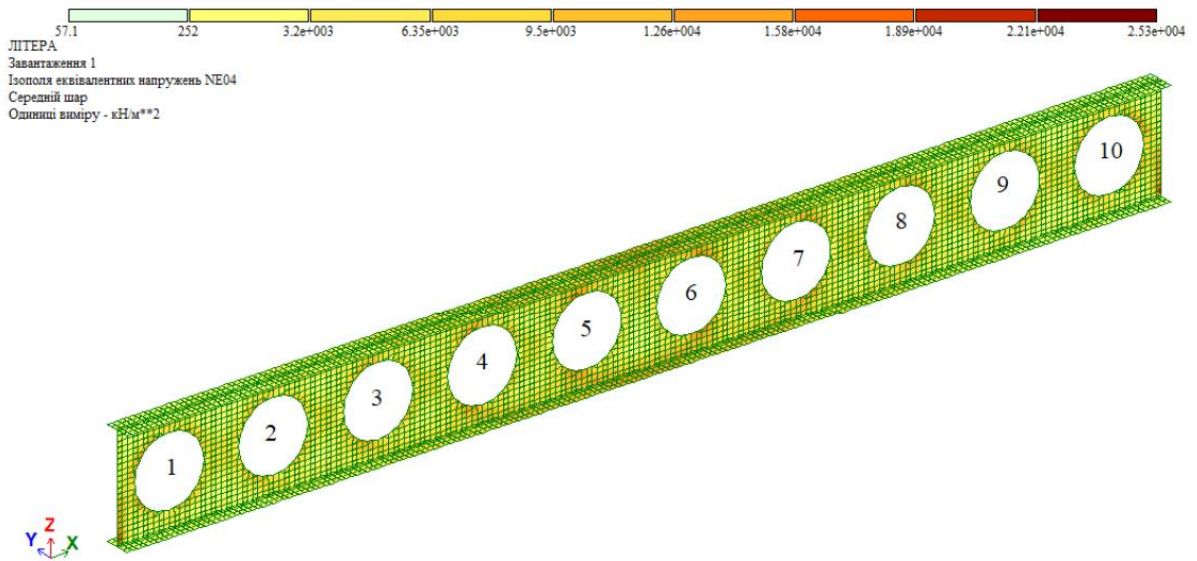

Figure 4. Values of equivalent stresses in a perforated beam without thickening of the finite mesh, kPa (LIRA)

The obtained results are shown in Table 1.

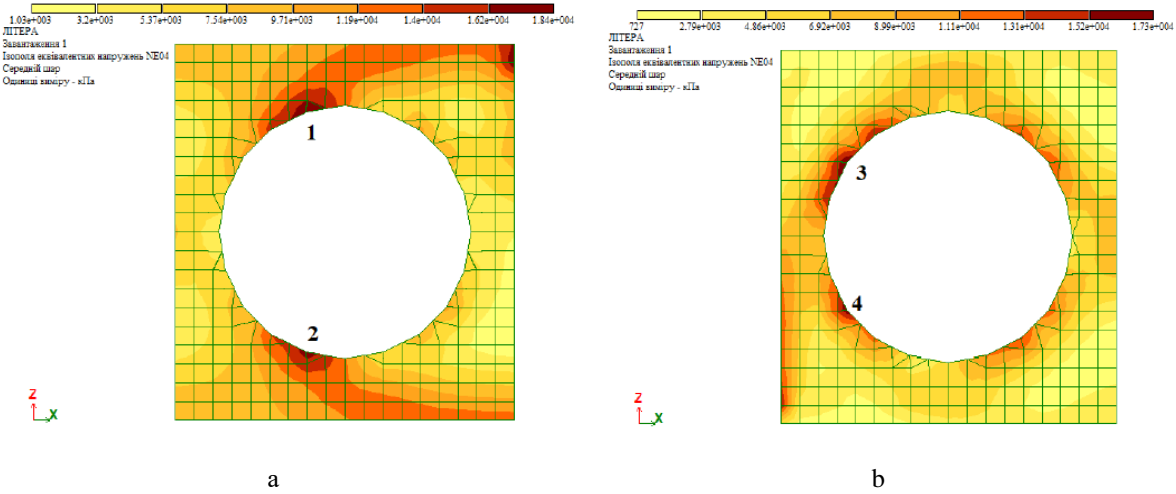

Figure 5. Equivalent stresses around holes No. 5 (a) and No. 1 (b) in a perforated beam (LIRA, model without finite elements mesh refinement)

Let's reduce the mesh size of finite elements at the edges of the perforation holes to 2 mm (see Figure 6) and determine how it will affect the stress-strain state of the beam.

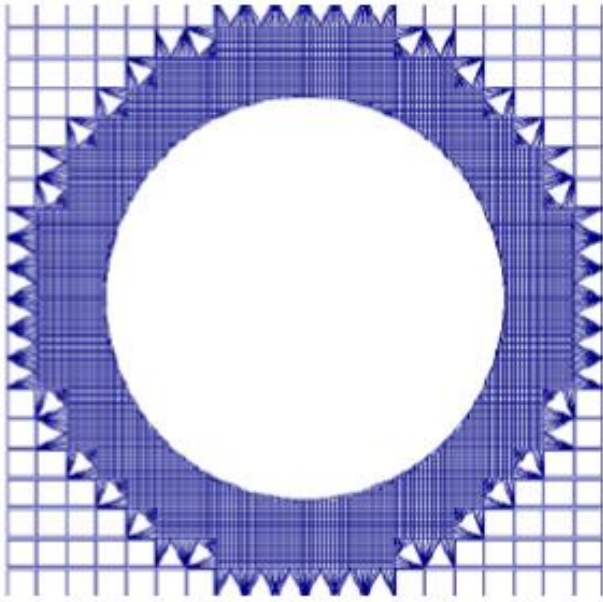

Figure 6. Finite elements mesh refinement on the contour of perforation holes (LIRA)

It should be noted that such selective mesh refinement allows for time-saving calculations and, in many cases, is the only feasible method considering the technical capabilities of personal computers.

We perform the calculation and obtain the values of the maximum deflection (Figure 7), as well as the equivalent stresses around the 5th and 1st holes (Figure 8 and 9, respectively) for the model with mesh refinement around the holes.

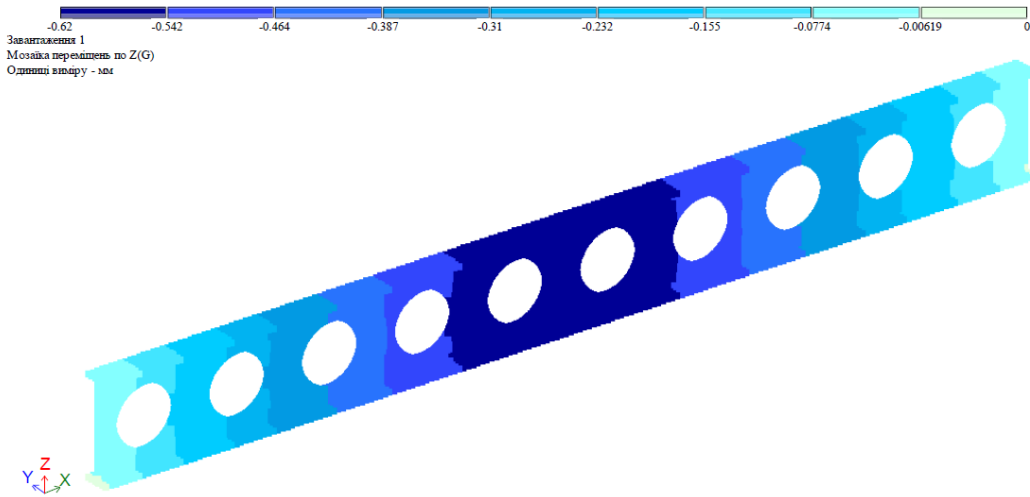

Figure 7. Assessment of the perforated beam deflection, mm

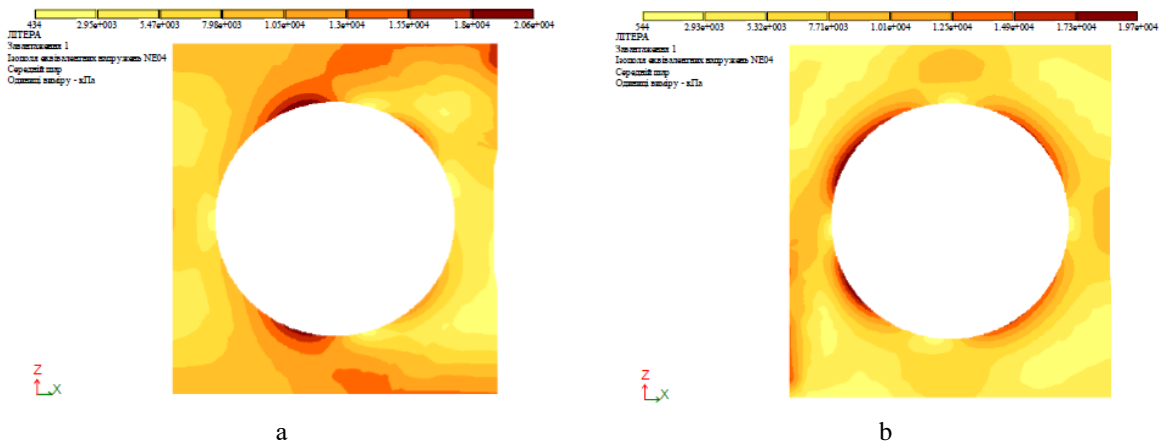

Figure 8. Equivalent stresses around holes No. 5 (a) and No. 1 (b) in a cellular beam, MPa (LIRA, model with mesh refinement around selected holes)

It should be noted that the results obtained with mesh refinement differ from the previous ones. We record them in Table 1 for further comparison.

The study of the stress-strain state of the steel perforated beam in the SolidWorks software package. Similar to the previous case, in the SolidWorks calculation package, we create the same beam with perforated web. In the first variant, we use a finite element mesh with 20 mm elements, and in the second variant, we use mesh refinement at the hole edges to 2 mm. We set the boundary conditions and repeat the calculation algorithm.

We obtain the deflection values (Figure 9) and equivalent stresses on the edges of the perforation holes (Figure 10).

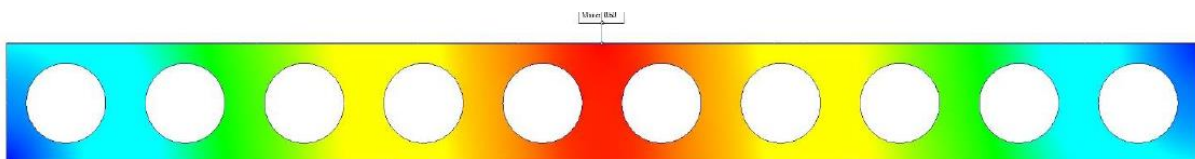

Figure 9. Estimated deflection of a perforated beam, mm (SolidWorks, model without finite elements mesh refinement)

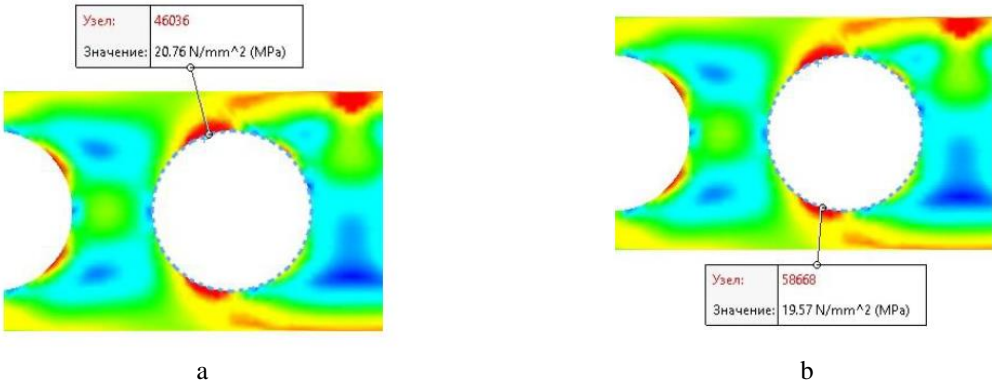

Figure 10. Equivalent stresses around holes No. 5 (a) and No. 1 (b) in a cellular beam, MPa (SolidWorks, beam model without mesh refinement)

Similarly, we create a beam with mesh refinement down to 2 mm around the contour of the perforation holes. The refinement is selectively applied around holes No. 1, No. 5, No. 6, and No. 10 (see Figure 11). We perform the calculation and obtain deflection values (Figure 12) and equivalent stresses (Figure 13).

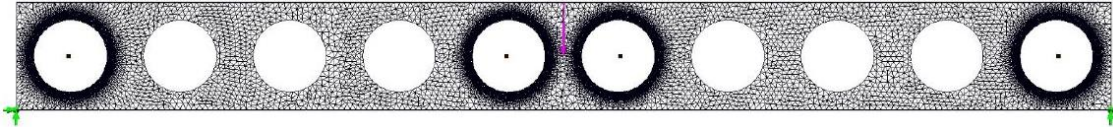

Figure 11. Calculation model of a beam with mesh refinement near the edge of selected holes (SolidWorks)

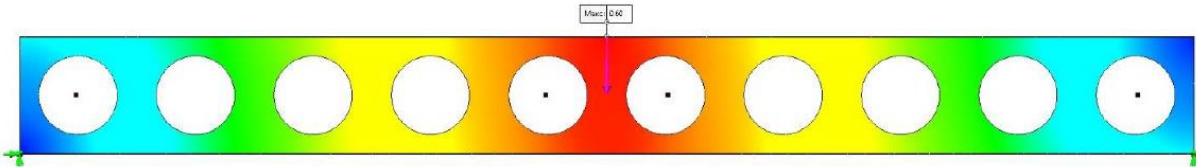

Figure 12. Estimated deflection of a cellular beam, mm (SolidWorks, beam model with finite elements mesh refinement near the edge of the selected holes)

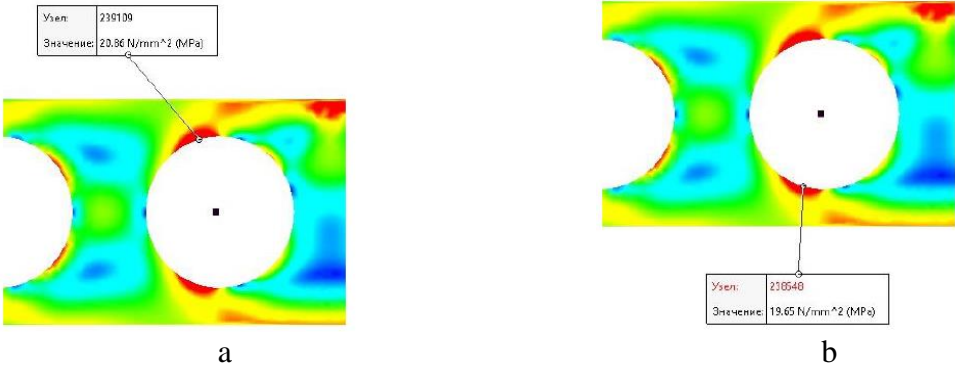

Figure 13. Equivalent stresses around holes No. 5 (a) and No. 1 (b) in the cellular beam, MPa (SolidWorks, model with finite elements mesh refinement around selected holes)

The study of the stress-strain state of the steel perforated beam in the ANSYS software package. Similarly, we create a calculation model of the perforated beam in the ANSYS software package. We define the material properties in the Workbench environment, create the beam's geometry in the SpaceClaim subsystem, set boundary conditions, and perform the structural analysis in the Mechanical module [17].

We create the first model with a finite element size of 20 mm. We perform the analysis and obtain deflection values (Figure 14) and equivalent stresses around the 5th and 1st holes (Figure 15).

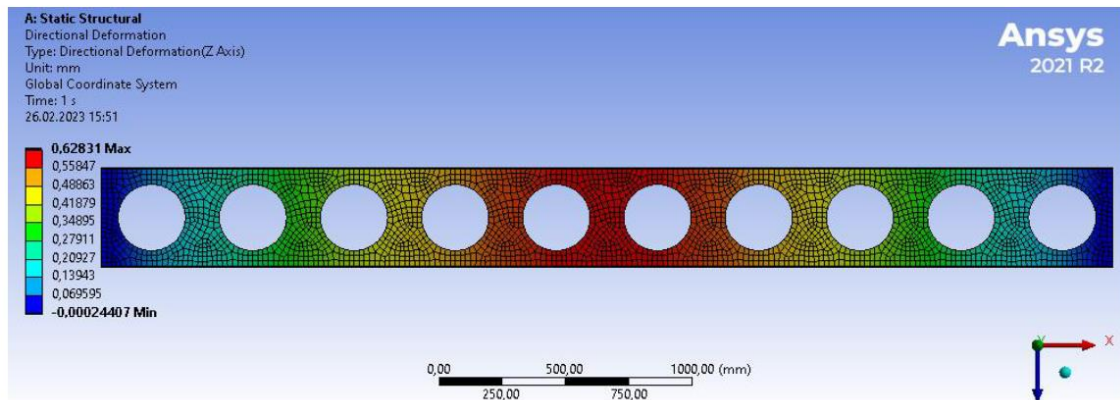

Figure 14. Estimated deflection of a cellular beam, mm (ANSYS, beam model without finite elements mesh refinement)

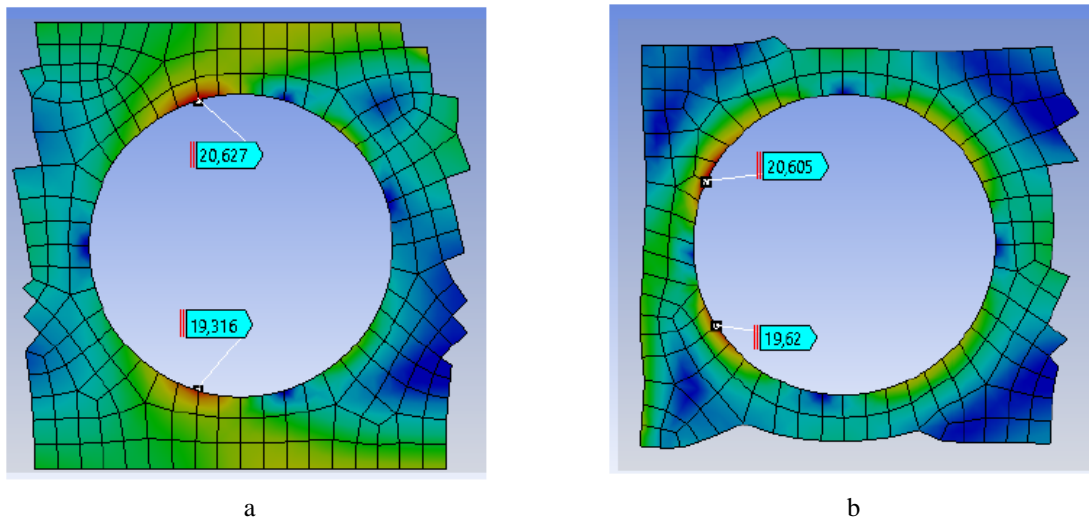

Figure 15. Equivalent stresses around holes No. 5 (a) No. 1 (b) in the cellular beam, MPa (ANSYS, model without mesh refinement)

Following the same approach as in the previous cases, we refine the finite element mesh at the edges of the perforation holes to 2 mm (see Figure 16). We perform the calculation and obtain deflection values (Figure 17) and equivalent stresses (Figure 18).

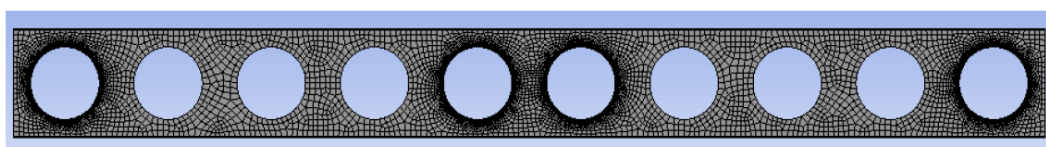

Figure 16. Calculation model of a beam with mesh refinement near the edge of selected holes (ANSYS)

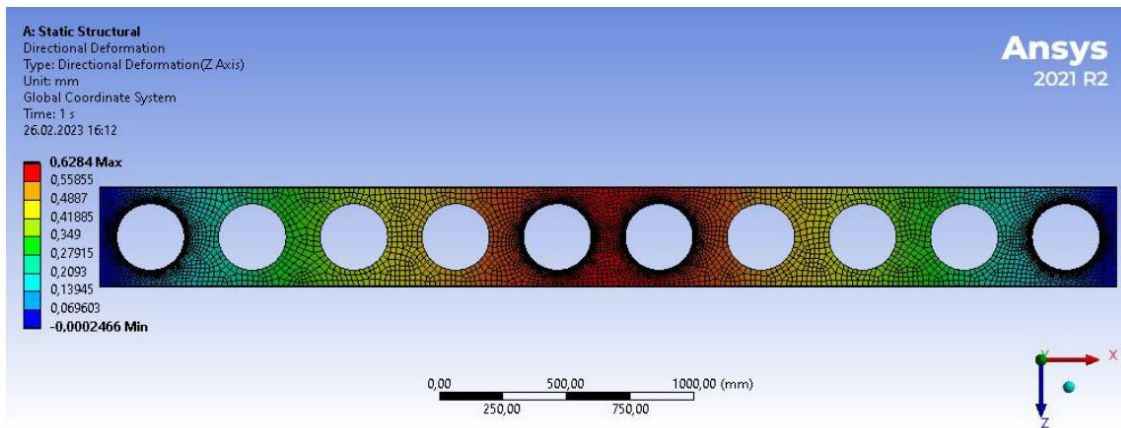

Figure 17. Estimated deflection of a cellular beam, mm (ANSYS, beam model with finite elements mesh refinement near the edge of the selected holes)

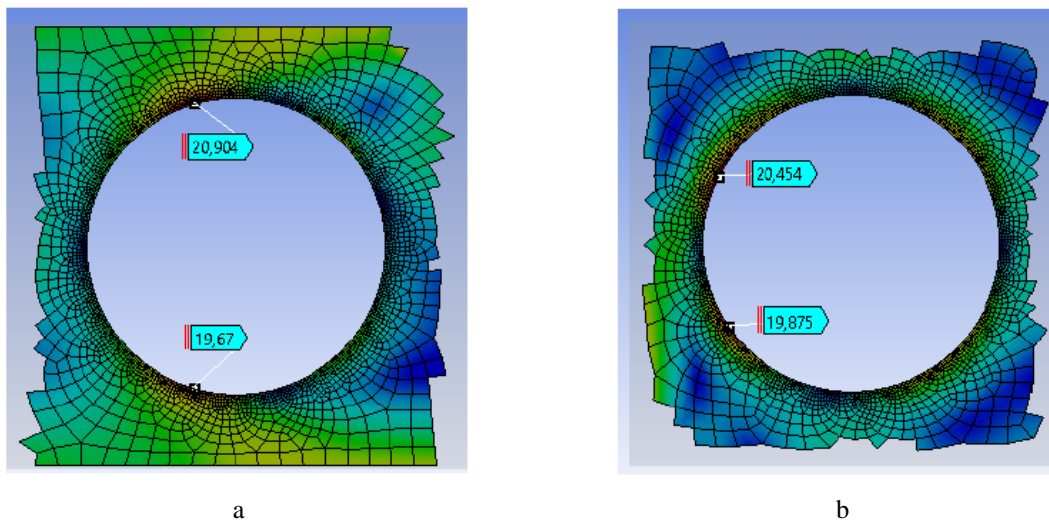

Figure 18. Equivalent stresses around holes No. 5 (a) and No. 1 (b) in the cellular beam, MPa (ANSYS, model with finite elements mesh refinement around selected holes)

The results obtained using the mentioned computational packages have been included into the comprehensive Table 1 and are presented in Figure 19 and Figure 20.

Table 1

The results of the SSS study of a steel beam with a perforated web in various software calculation complexes

Software complex		LIRA		SolidWorks		ANSYS	
FE size, mm		20	20 (on the edge 2)	20	20 (on the edge 2)	20	20 (on the edge 2)
Equivalent stress at points*, MPa	1	19,344	20,687	20,760	20,860	20,627	20,904
	2	18,170	19,466	19,570	19,650	19,316	19,670
	3	19,249	19,883	19,790	20,460	20,605	20,454
	4	18,753	19,857	19,250	19,890	19,620	19,875

*Note: the points at which the equivalent stresses are determined correspond to those depicted in Figure 5.

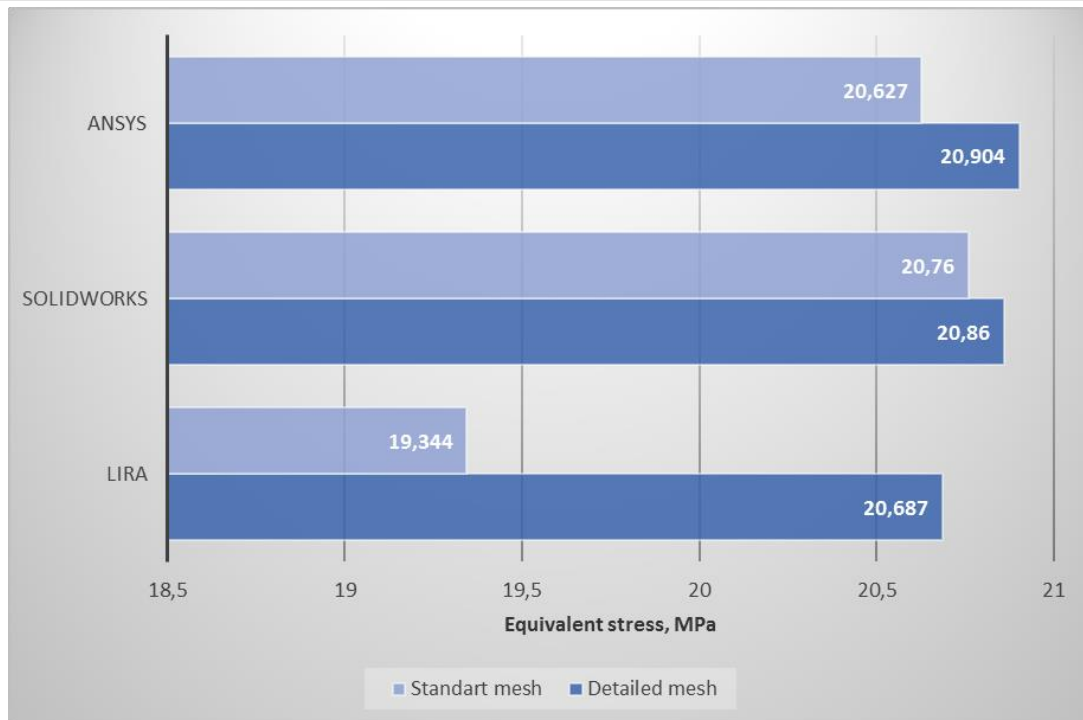

Figure 19. Maximum equivalent stresses around the perforation holes for different software complexes and variable finite elements mesh

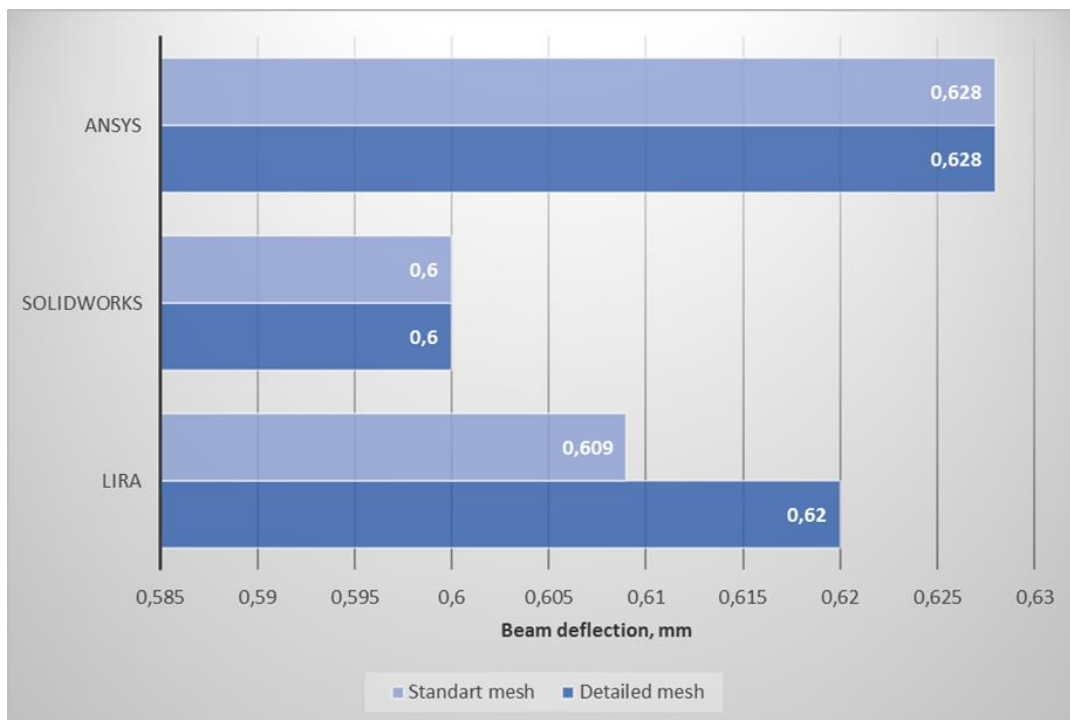

Figure 20. Maximum beam deflections for various software complexes and variable finite elements mesh

Analyzing the maximum equivalent stresses obtained at the investigated points on the contour of the holes, the following conclusions can be made:

- mesh refinement around the holes leads to significant refinement of stresses, with values obtained using the LIRA software (by 6.5%); in other software packages (SolidWorks, ANSYS), the change in these values does not exceed 1.3%;

- when using a fine mesh, the stress values obtained on the hole contour in all three investigated programs are close and differ by no more than 1.04%;
- when calculating the deflections of beam models with a 20 mm finite element mesh (Model 1) and the same finite element mesh with simultaneous refinement to 2 mm near the hole edges (Model 2), identical results were obtained in ANSYS and SolidWorks (i.e., the mesh refinement did not affect their values). In contrast, in LIRA, when refining the mesh, the deflection values increased by 1.78%;
- in the beam model with a 20 mm finite element mesh (Model 1) and the same finite element mesh with simultaneous refinement to 2 mm at the edges of the perforation holes (Model 2), the deviations in deflection values in LIRA are 1.27%, in SolidWorks – 4.45%, compared to the data obtained in the ANSYS program.

Conclusions. Taking into account the results of the comparative analysis of the stress-strain state investigation of beams with circular openings in the web, it can be concluded that these analyses can be performed in any of the presented software packages: ANSYS, LIRA, SolidWorks, provided that a well-developed research methodology is employed. The error in the results of the finite element method analysis in the mentioned software programs does not exceed 5%.

References

1. Sameer S. Fares P. E., S.E., P. Eng, John Coulson, P.E., David W. Dinehart, Ph.D. Design Guide 31: Castellated and Cellular Beam Design (2016) American Institute of Steel Construction, 110 pages.
2. ACB and Angelina beams. A new generation of beams with large web openings. ArcelorMittal Europe – Long products. ArcelorMittal, Luxembourg, 2020. 64 p.
3. The Westok Cellural Beam Pocket Guide. Kloeckner Metals UK. Westok, London, 2020. 36 p.
4. Nilov O. O., Permiakov V. O., Shymanovskiy O. V., Bilyk S. I., Lavrynenko L. I., Bielov I. D., Volodymyrskiy V. O. Metalevi konstruksii. Zahalnyi kurs: pidruchnyk. K.: Vydavnytstvo „Stal”, 2010. 869 p. [In Ukrainian].
5. Pidgurskyi I., Slobodian V., Bykiv D., Pidgurskyi M. Investigation of the stress-strain state of beams with different types of web perforation. Scientific Journal of TNTU. 2021. Vol. 103. No. 3. P. 79–87. https://doi.org/10.33108/visnyk_tntu2021.03.079
6. British Standards Institution BS 5950: Structural use of steelwork in building. Part 1: Code of practice for design – Rolled and welded sections.
7. DBN V.2.6–198:2014 Stalevi konstruksii. Normy proektuvannia. [Na zaminu DSTU B V.2.6-194:2013 ta DBN V.2.6-163:2010. Chynnyi vid 01.01.2015]. Vyd. ofits. Kyiv: Minrehion Ukrainy, 2014. 209 p. [In Ukrainian].
8. Blodgett Omer W. (1996) Design of Welded Structures. Lincoln Arc Welding Foundation, Cleveland OHIO. 832 p.
9. Elaiwi, Sahar & Kim, Boksun & Li, Long-Yuan. (2019). Bending Analysis of Castellated Beams. Athens Journal of Technology & Engineering. 6. 1-16. <https://doi.org/10.30958/ajte.6-1-1>
10. Sheena N. (2017). Deflection, stress distributions and modes of failure of cellular beams. 304 p.
11. Manoharan A. C., Tripathi R.K., Analysis of steel beams with circular opening International Journal of Civil Engineering and Technology (IJCIET). 2017. 8 (3). P. 411–422.
12. Warren J. (2001). Ultimate load and deflection behaviour of cellular beams. MSc thesis. School of Civil Engineering, University of Natal, Durban.
13. Romaniuk V. V., Supruniuk V. V., Bezniuk L. I., Romaniuk V. V., Supruniuk V. V., Bezniuk L. I. (2021). Napruzhenno-deformovanyi stan nerozriznykh perforovanykh balok bilia promizhnykh opor. Visnyk Natsionalnoho universytetu vodnoho hospodarstva ta pryrodokorystuvannia. (1(93)). P. 405–416. [In Ukrainian].
14. Dutt A. Effect of mesh size on finite element analysis of beam. International Journal of Mechanical Engineering. 2 (12). 2015. P. 8–10. <https://doi.org/10.14445/23488360/IJME-V2I12P102>
15. Pachpor P. D., Gupta L. M. and Deshpande N. V., DzAnalysis and design of cellular beam and its verificationdz, 2013 International Conference on Applied Computing, Computer Science and Computer Engineering. IERI Procedia. 2014. Vol. 7. P. 120–127. <https://doi.org/10.1016/j.ieri.2014.08.019>
16. Matt Lombard Mastering SolidWorks, 2018. 1248 p. <https://doi.org/10.1002/9781119516743>
17. Lee H. H. Finite Element Simulations with ANSYS Workbench 19, SDC Pub., 2019, 644 p.
18. Barabash M. S., Kozlov S. V., Medvedenko D. V. Kompiuterni tekhnolohii proektuvannia metalevykh konstruksii: Navchalnyi posibnyk. K.: NAU, 2012. 572 p. [In Ukrainian].

Список використаних джерел

1. Sameer S. Fares P. E., S.E., P. Eng, John Coulson, P.E., David W. Dinehart, Ph.D. Design Guide 31: Castellated and Cellular Beam Design (2016) American Institute of Steel Construction, 110 pages.
2. ACB and Angelina beams. A new generation of beams with large web openings. ArcelorMittal Europe – Long products. ArcelorMittal, Luxembourg, 2020. 64 p.
3. The Westok Cellural Beam Pocket Guide. Kloeckner Metals UK. Westok, London, 2020. 36 p.
4. Нілов О. О., Пермяков В. О., Шимановський О. В., Білик С. І., Лавриненко Л. І., Белов І. Д., Володимирський В. О. Металеві конструкції: Загальний курс. К.: Видавництво «Сталь», 2010. 869 с.
5. Pidgurskyi I., Slobodian V., Bykiv D., Pidgurskyi M. Investigation of the stress-strain state of beams with different types of web perforation. Scientific Journal of TNTU. 2021. Vol. 103. No. 3. P. 79–87. https://doi.org/10.33108/visnyk_tntu2021.03.079
6. British Standards Institution BS 5950: Structural use of steelwork in building. Part 1: Code of practice for design – Rolled and welded sections
7. ДБН В.2.6–198:2014 Сталеві конструкції. Норми проектування. [На заміну ДСТУ Б В.2.6-194:2013 та ДБН В.2.6-163:2010. Чинний від 01.01.2015]. Вид. офіц. Київ: Мінрегіон України, 2014. 209 с.
8. Blodgett Omer W. (1996) Design of Welded Structures. Lincoln Arc Welding Foundation, Cleveland OHIO. 832 p.
9. Elaiwi, Sahar & Kim, Boksun & Li, Long-Yuan. (2019). Bending Analysis of Castellated Beams. Athens Journal of Technology & Engineering. 6. 1-16. <https://doi.org/10.30958/ajte.6-1-1>
10. Sheena N. (2017). Deflection, stress distributions and modes of failure of cellular beams. 304 p
11. Manoharan A. C., Tripathi R.K., Analysis of steel beams with circular opening International Journal of Civil Engineering and Technology (IJCIET). 2017. 8 (3). P. 411–422.
12. Warren J. (2001). Ultimate load and deflection behaviour of cellular beams. MSc thesis. School of Civil Engineering, University of Natal, Durban
13. Romaniuk V. V., Supruniuk V. V., Bezniuk L. I., Romaniuk V. V., Supruniuk V. V., Bezniuk L. I. (2021). Napruzhenno-deformovanyi stan nerozriznykh perforovanykh balok bilia promizhnykh opor. Visnyk Natsionalnoho universytetu vodnoho hospodarstva ta pryrodokorystuvannia. (1(93)). P. 405–416. [In Ukrainian].
14. Dutt A. Effect of mesh size on finite element analysis of beam. International Journal of Mechanical Engineering. 2 (12). 2015. P. 8–10. <https://doi.org/10.14445/23488360/IJME-V2I12P102>
15. Pachpor P. D., Gupta L. M. and Deshpande N. V., DZAnalysis and design of cellular beam and its verification, 2013 International Conference on Applied Computing, Computer Science and Computer Engineering. IERI Procedia. 2014. Vol. 7. P. 120–127. <https://doi.org/10.1016/j.ieri.2014.08.019>
16. Matt Lombard Mastering SolidWorks, 2018. 1248 p. <https://doi.org/10.1002/9781119516743>
17. Lee H. H. Finite Element Simulations with ANSYS Workbench 19, SDC Pub., 2019, 644 p.
18. Барабаш М. С., Козлов С. В., Медведенко Д. В. Комп'ютерні технології проектування металевих конструкцій: навчальний посібник. К.: НАУ, 2012. 572 с.

УДК 624.014

**ОСОБЛИВОСТІ ДОСЛІДЖЕННЯ НАПРУЖЕНО-ДЕФОРМІВНОГО
СТАНУ БУДІВЕЛЬНИХ СТАЛЕВИХ ПЕРФОРОВАНИХ БАЛОК
МЕТОДОМ СКІНЧЕНИХ ЕЛЕМЕНТІВ**

**Микола Підгурський; Іван Підгурський; Микола Сташків;
Вікторія Ігнат'єва; Світлана Данильченко; Денис Биків;
Олег Підлужний**

*Тернопільський національний технічний університет імені Івана Пулюя,
Тернопіль, Україна*

Резюме. Проаналізовано переваги та недоліки перфорованих балок, наведено області їх застосування в будівництві при зведенні та реконструкції будівель і споруд. Наведено огляд конструктивних рішень перфорованих балок, що застосовуються в будівництві, який вказує на велике різноманіття їх форм та розташування їх вирізів. Вказано, що найоптимальніші варіанти перфорованих

балок можливі лише після аналізу впливу різних елементів конструктивного оформлення на напружено-деформівний стан та стійкість балок. Сюди віднесено вид перфорації – одно- чи дворядну; форму вирізів – шестикутну, круглу, овальну, синусоїдальну та ін., взаємне розташування вирізів, а також їх відносну висоту. Кожна з форм вирізів має свої переваги та недоліки. Зазначено, що для оптимального використання перфорованих балок, які мають різну конфігурацію вирізів у стінці, проводять дослідження їх напружено-деформівного стану та стійкості. Одним з найефективніших методів розрахунку перфорованих балок з новими видами вирізів є метод скінчених елементів. Проведено порівняльні дослідження прогинів балок та оцінювання напружень у зонах круглих отворів за допомогою сучасних спеціалізованих програм ANSYS, SolidWorks, ЛІРА-САПР. На основі літературного огляду встановлено, що важливим чинником для отримання точних результатів досліджуваних параметрів має розмір сітки скінчених елементів. Застосовано дві моделі створення сітки скінчених елементів: регулярну з розміром скінченого елемента 20 мм та модифіковану – з глобальною сіткою скінчених елементів 20 мм та для деталізації зон концентрації напружень біля кромок отворів зі згущенням елементів розміром 2 мм. Застосування модифікованої сітки скінчених елементів дозволило уточнити величину прогинів та напружень у досліджуваних програмних комплексах при раціоналізації часу обчислень.

Ключові слова: перфоровані балки, напружено-деформівний стан, метод скінчених елементів, модифікована сітка скінчених елементів.

https://doi.org/10.33108/visnyk_tntu2023.03.126

Отримано 10.06.2023