

UDC 539.12.04, 628.9

THE METHOD OF NANOTUBES CAUSING ON POLYTETRAFLUOROETHYLENE FILMS SURFACE

Vitalii Mocharskyi; Oksana Sitkar; Bohdan Kovalyuk

Ternopil Ivan Puluj National Technical University, Ternopil, Ukraine

Summary. A new method of nanotubes causing on the surface of polytetrafluoroethylene (PTFE) films using a device for laser shock-plasma acceleration of finely dispersed materials was developed in this work. The formed structures were investigated using scanning electron microscopy. The transmission spectra of the formed films were studied. Physical mechanisms during coating application and changes in transmission spectra are explained.

Key words: films, laser, carbon nanotubes.

https://doi.org/10.33108/visnyk_tntu2022.04.117

Received 06.12.2022

Statement of the problem. Today, electronic devices and their components are widely used in all fields of science and technology. The application of flexible electronics in modern technology is of great interest, as it makes it more compact, less material-intensive and less energy-consuming. In recent decades, nanotubes have also been used to manufacture new electronic components. Different methods and technologies are used to manufacture flexible electronics components. It is of interest to use laser methods of nanotubes causing on the surface of flexible substrates (polytetrafluoroethylene films) with the aim of further application of such components in microelectronics and nanoelectronics.

Analysis of the available investigations. Nanotubes have a number of advantages over traditional materials, the main of which are: low resistance, high conductivity, high electron work, high elastic properties, etc. [1–2] The presence of these properties contributed to the fact that nanotubes find their application in new fields of electronics, microelectronics and nanoelectronics: the manufacture of electric batteries, optical fibers, various sensors, etc. [3–5]. Considering the literary sources, it can be said that the problem of creating new electronic components is actual. We conducted preliminary studies on laser implantation of nanotubes into the surface of aluminum, which showed the prospects of using lasers for such processing [6].

The Objective of the work is to develop a method of reliable nanotubes causing on the surface of flexible substrates using laser radiation and to study the properties of the formed films.

Statement of the task. Research on the possibility of applying the method of nanotubes causing on the surface of polytetrafluoroethylene (PTFE) films using a device for laser shock-plasma acceleration of finely dispersed materials.

Experimental model. A special device for laser shock-plasma acceleration of finely dispersed materials was used for the nanotubes causing on PTFE films (fig. 1) [7].

The radiation of the laser 1 in the Q-switched mode is focused by the optical system 2 through the transparent plate 3 on the nanotubes 8, which is placed in the groove 7 of the additional transparent plate 6 attached with the help of glue 5. The energy flow density of the laser pulse is regulated within the range of $5 \times 10^8 \text{ W/cm}^2$ to $2 \times 10^9 \text{ W/cm}^2$.

As a result of the high density of the flow, part of the nanotubes turns into a plasma state. The high rate of plasma formation and the limited volume for its expansion form a «shock piston» that accelerates and sprays the nanotubes 8 through the groove 7 onto the surface of the PTFE film 3. By changing the geometric dimensions and shape of the groove, the required nanotubes flow parameters can be achieved.

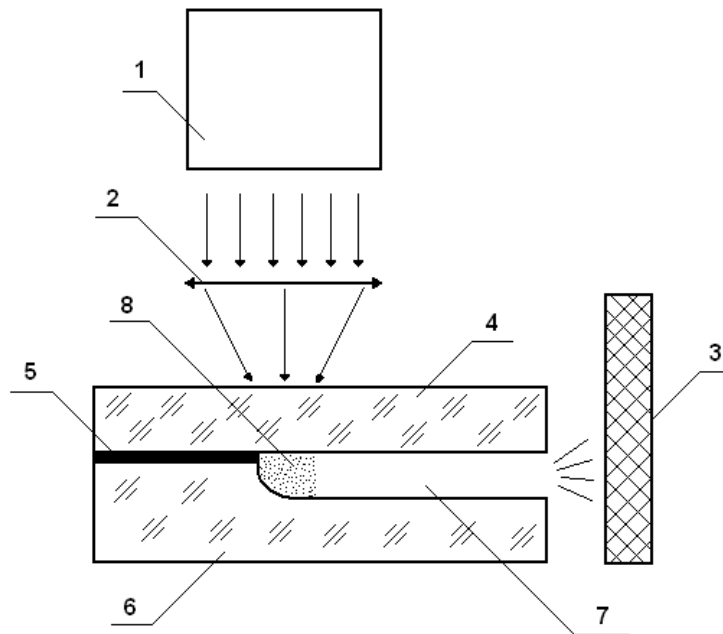

Figure 1. Device for laser shock-plasma acceleration of finely dispersed materials:
1 – laser, 2 – optical system, 3 – PTFE film, 4 – transparent plate, 5 – glue,
6 – additional transparent plate, 7 – slot, 8 – nanotubes.

The proposed method using a device for shock-plasma acceleration of finely dispersed materials allows nanotubes causing on flexible substrates, which is a variation of the method of laser deposition of films, as in lithography.

According to estimates, the average speed with which the nanotubes flew out was ≥ 2 km/s, and the energy per carbon atom was 0.8 eV, which is an order of magnitude lower than the interatomic bond energy of carbon nanotubes (6 eV). Therefore, only a part of the carbon atoms goes into the plasma state under the action of the laser pulse, but this leads to an increase in pressure and the formation of an elastic wave, as a result of which the carbon atoms fly out of the groove and are caused on surface of the PTFE film.

Nanotubes causing was carried out in two types of PTFE films. The thickness of the films were 40 microns and 80 microns (Fig. 2). As can be seen in fig. 2 d, the coating after application has the appearance of wavy periodic structures with the thickness of combs 1–3 μm , in addition, there are more transparent areas without nanotubes, which are clearly visible in the image, caused by the breaking of bonds in the film during an ultrafast impact. From fig. 2 e, we can see that the thickness of the applied coating is 20 μm .

The coating was formed by the ultra-fast collision of nanotubes and their parts with a PTFE film. A large number of atoms simultaneously fall on a small area of the surface and a large amount of energy is concentrated, which leads to ultra-fast deformations and heating of both parts of the nanotubes and the film. Thus, in the collision zone, extreme conditions arise under which highly unbalanced physicochemical processes are induced (emission and ionization of charged particles, generation of radiation and microshock waves, breaking and establishment of interatomic bonds), which are not realized under normal thermal conditions.

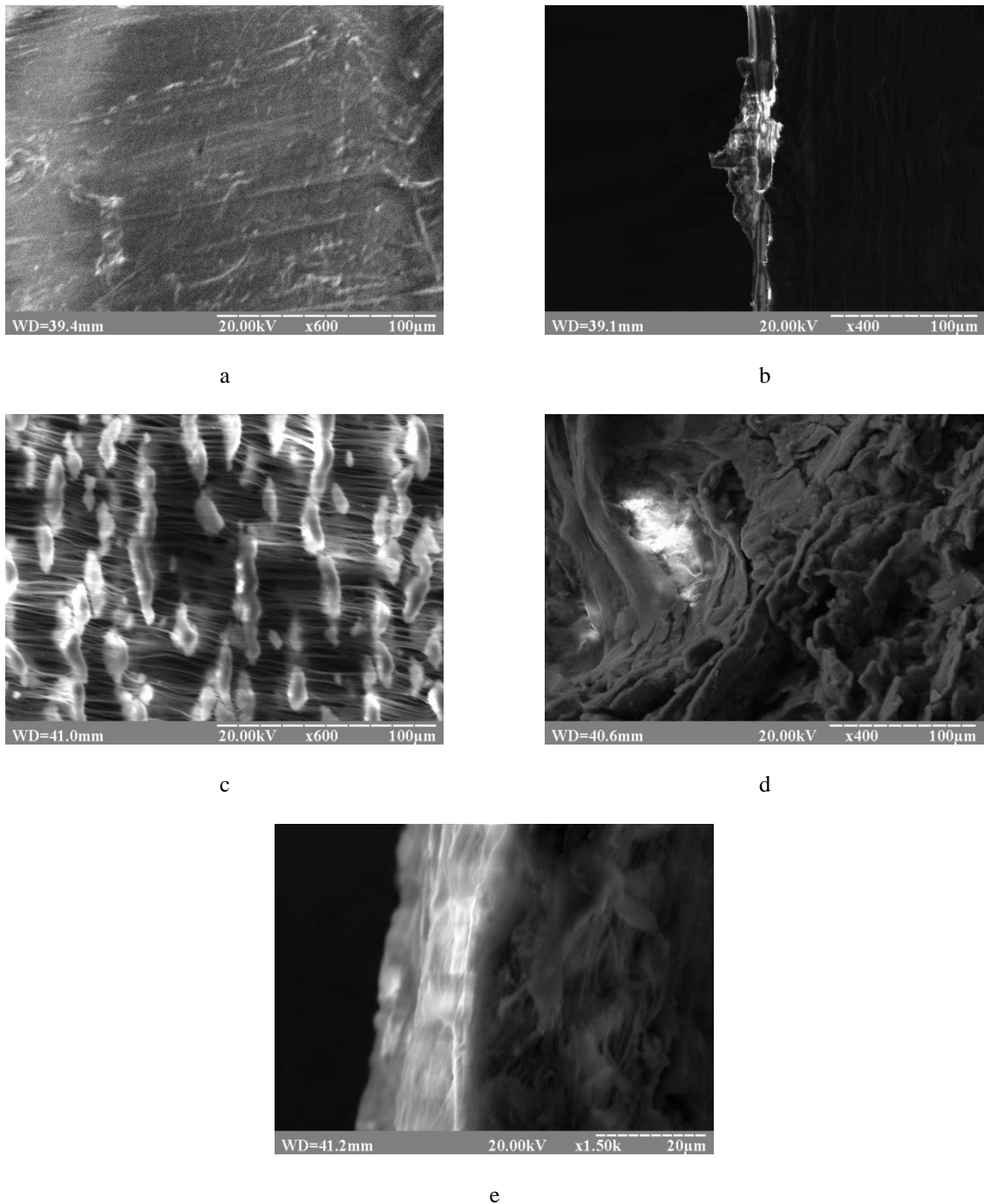

Figure 2. Surface of PTFE films before and after nanotubes causing:
 a – thick film (80 μm) before causing, b – the end of a thick film after implantation,
 c – thin film (40 μm) before implantation, d, e – surface and end of the thin film after implantation

The optical transmittance spectra of the films before and after the nanotubes causing were studied using a photometer. The study of the optical transmittance of PTFE films before and after application is shown in fig. 3. As can be seen from the figure, in absolute units, the transmission spectra of the films before and after the nanotubes causing practically repeat each other. But in relative units (Fig. 4) it can be seen that the transmittance spectrum of the thin film has practically not changed and is within the margin of error, and the transmittance spectrum of the thick film at wavelengths of 500–800 nm has increased (maximum 10% at the wavelength of 600 nm).

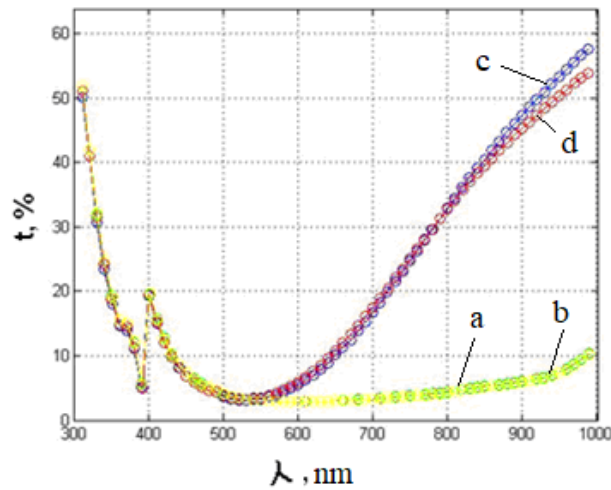

Figure 3. Transmission spectra of PTFE films without nanotubes and with nanotubes: a – clean thin film, b – thin film with nanotubes, c – clean thick film, d – thick film with nanotubes

The decrease in transmission is easily explained by the increase in the thickness of the films after the nanotubes causing and the decrease in transparency, which leads to an increase in absorption and scattering. The increase in transmittance is possibly associated with increased transparency areas on the surface of the film, but since their number is small, their contribution to the integral characteristic is negligible. Most likely, it can be assumed that the increase in transmission is related to the reduction of Fresnel losses on the film surface from several percent to tens of percent.

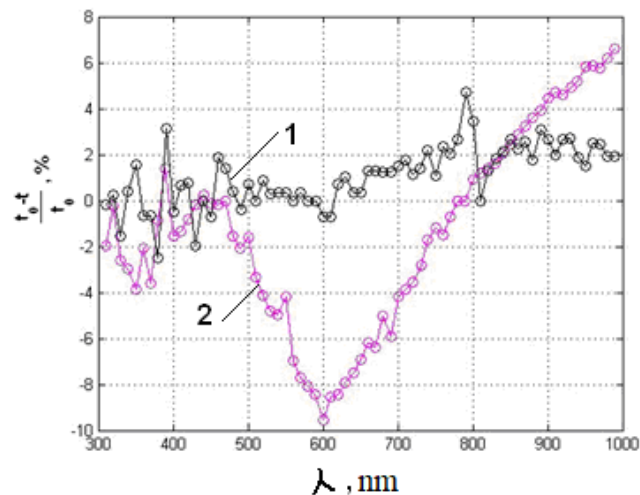

Figure 4. Change in transmission spectra in relative units: 1 – thin film; 2 – thick film

Conclusions. A new method of nanotubes causing on flexible substrates (PTFE films) using a device for laser shock-plasma acceleration of finely dispersed materials has been developed.

Scanning electron microscopy shows that a strong adhesive bond is formed between the caused nanotubes and the PTFE substrate.

The transmission spectra of the obtained films were determined and the mechanism of their change due to the reduction of Fresnel losses on the surface of the PTFE film with caused nanotubes was explained.

References

1. Bernholc J., Brenner D., Buongiorno Nardelli M., Meunier V., Roland C. Mechanical and electrical properties of nanotubes. Annual Review of Materials Science. 2002. 32. P. 347–375. <https://doi.org/10.1146/annurev.matsci.32.112601.134925>
2. Maheswaran R., Shanmugavel B. P. A Critical Review of the Role of Carbon Nanotubes in the Progress of Next-Generation Electronic Applications. J. Electron. Mater. 2022. 51. P. 2786–2800. <https://doi.org/10.1007/s11664-022-09516-8>
3. Jyoti J., Gupta T. K., Singh B. P., Sandhu M., Tripathi S. K. Recent advancement in three dimensional graphene-carbon nanotubes hybrid materials for energy storage and conversion applications. Journal of Energy Storage. 2022. 50.104235. <https://doi.org/10.1016/j.est.2022.104235>
4. Lekawa-Raus A., Patmore J., Kurzepa L., Bulmer J., Koziol K. Electrical properties of carbon nanotube based fibers and their future use in electrical wiring. Advanced Functional Materials. 2014. 24 (24). P. 3661–3682. <https://doi.org/10.1002/adfm.201303716>
5. Nag A., Mukhopadhyay S. C. Fabrication and implementation of carbon nanotubes for piezoresistive-sensing applications: A review. Journal of Science: Advanced Materials and Devices. 2022. 7 (1). 100416. <https://doi.org/10.1016/j.jsamd.2021.100416>
6. Sitkar, O., Kovalyuk, B., Mocharskyi V. Mathematical Modeling of The Nanotubes Implementation into A Solid-State Matrix Using A Powerful Laser. CEUR Workshop Proceedings, 2022, 3309, pp. 160–164.
7. Mocharskyi V. S., Nikiforov Yu. M., Kovalyuk B. P. Patent 86399 Ukraine, IPC C23C 24/00. Device for laser shock-plasma acceleration of finely dispersed materials. № u201308851; statement 07/15/2013; published 25.12.2013, Bul. No. 24. 4 p.

УДК 539.12.04, 628.9

МЕТОД НАНЕСЕННЯ НАНОТРУБОК НА ПОВЕРХНІ ПОЛІТЕТРАФТОРЕТИЛЕНОВИХ ПЛІВОК

Віталій Мочарський; Оксана Сіткар; Богдан Ковалюк

*Тернопільський національний технічний університет імені Івана Пулюя,
Тернопіль, Україна*

Резюме. На сьогодні електронні пристрої та їх компоненти знайшли широке застосування в усіх галузях науки і техніки. Великий інтерес представляє застосування гнучкої електроніки в сучасній техніці, оскільки це робить її компактнішою, менш матеріаломісткою та менш енергозатратною. Останні десятиліття для виготовлення нових компонентів електроніки також застосовують нанотрубки. Для виготовлення компонентів гнучкої електроніки застосовують різні методи та технології. Цікавим є застосування лазерних методів нанесення нанотрубок на поверхні гнучких підкладок (політетрафторетиленових плівок) з метою подальшого застосування таких компонентів у мікроелектроніці й наноелектроніці. Нанотрубки володіють рядом переваг над традиційними матеріалами, основні з яких: низький опір, висока провідність, висока робота виходу електронів, високі пружні властивості тощо. Наявність цих властивостей сприяла тому, що нанотрубки знаходять своє застосування в нових галузях електроніки, мікроелектроніки і наноелектроніки: виготовлення електричних батарей, оптоволоконна, різноманітних сенсорів та ін. Розроблення методу надійного нанесення нанотрубок на поверхню гнучких підкладок із використанням лазерного випромінювання та дослідження властивостей утворених плівок. У роботі розроблено новий спосіб нанесення нанотрубок на поверхні політетрафторетиленових плівок із використанням приладу для лазерного ударно-плазмового прискорення дрібнодисперсних матеріалів. За оцінками, середня швидкість, з якою вилітали нанотрубки, становила ≥ 2 км/с. Нанесення нанотрубок проводили у два типи політетрафторетиленових плівок. Товщина плівок – 40 та 80 мкм. Покриття утворилося при надшвидкому зіткненні нанотрубок та їх частин з політетрафторетиленою плівкою. Досліджено спектри оптичного пропускання політетрафторетиленових плівок до та після нанесення. Показано підвищення пропускання в діапазоні довжин хвиль від 500 до 800 нм. Це пояснюється появою просвітлених ділянок на поверхні плівки внаслідок ультрашвидкого зіткнення та зменшеннями втрат Френеля на поверхні плівки з кількох відсотків до десятих відсотка.

Ключові слова: вуглецеві нанотрубки, лазер, плівки.

https://doi.org/10.33108/visnyk_tntu2022.04.117

Отримано 06.12.2022