



UDC 621.86

SUBSTANTIATION OF THE PARAMETERS OF HYDRAULIC OVERLOAD CLUTCH

**Roman Marchuk¹; Roman Komar¹; Taras Dubynyak¹; Oleg Flonts²;
Volodymyr Dynya²; Ivan Semeniv²**

¹*Ternopil Ivan Puluj National Technical University, Ternopil, Ukraine*
²*Separated unit of National University of Life and Environmental Sciences
„Berezhany Agrotechnical Institute“, Berezhany, Ukraine*

Summary. *Creation of new types of machines and mechanisms of transport and technological systems and their drives contributes to further economic development and expansion of the range, increase productivity through the introduction of scientific and technological progress.*

New design of hydraulic overload clutch with hypersensitivity has been presented, analytical dependence for determining the estimated torque depending on power and design parameters have been derived.

Key words: *hydraulic overload clutch, torque.*

Received 05.04.2017

Problem setting. To protect working parts of screw conveyors safety clutches of different design are widely used. Therefore, to reduce the dynamic loads in the process of locomotive wheel-slip and to provide more security of screw mechanisms from overload hydraulic protective clutch with hypersensitivity has been developed, in which the costs of contacting friction surfaces have been significantly reduced.

Analysis of recent researches. The issues of protection of drive hardware and mechanisms from overload the works of Polyakov V.S. [1], Rahovskiy O.A. [2], V.K. Tepynkechyev [3], V.A. Malashchenko [4], Pavlyshe V.T. [5], Nagornjak S.G. [6], Rogatynskiy R.M. [7], B.M. Hevko [8], Flick E.P. [9], Hevko R.B. [10] and many others have been dedicated. However, a number of issues connected with the increased sensitivity of safety clutches need to be solved. Therefore, the topic is relevant and is of great importance to improve their designs.

Setting targets. Improving the accuracy of hydraulic operation safety clutches by reducing the friction forces in the mechanism.

Statement of the material. For protection of working parts of screw conveyors overload clutches with hypersensitivity are used. Figure1. shows the design of the hydraulic overload clutch with hypersensitivity, which is designed as a driven half clutch, which consists of two parts, which are mounted on the drive shaft 2 via a spherical bearing 3 and rigidly connected with a driving star. At the end of the drive shaft 2 is a hinged installed driving half clutch, which is designed as a disc 5 and is supported in an inclined axis of rotation to the clutch position 6 by fingers, which are in contact with their spherical surfaces.

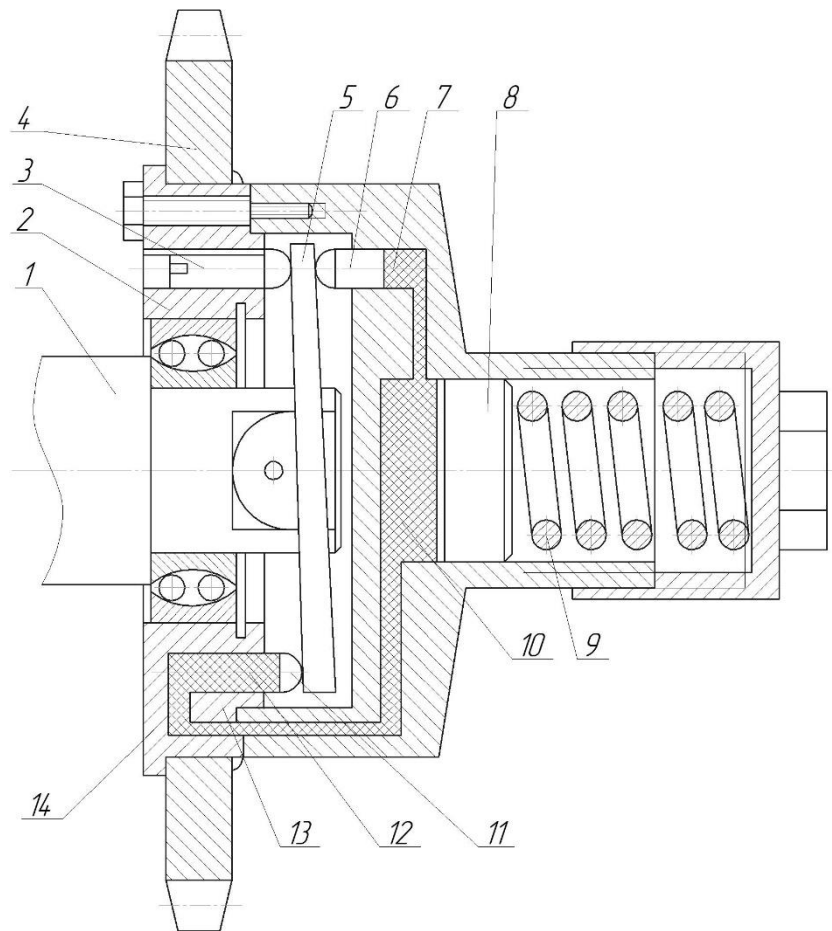

Figure 1. Hydraulic overload clutch with hypersensitivity [11]

The peculiarity of the structures fingers 6 is that, at their tops are rolled balls 7 which are in contact with a solid lubricant to grease them. The fingers 6 are installed in the opposite longitudinal channels 8, and are made in driven half clutch and are connected with a central hole 9, where the piston 10 is established. The space between the fingers 6 and piston 10 is filled with viscous fluid 11 for example with hydro-plastic. The piston 10 is spring loaded axially with the spring 12 the force of which is regulated with the nut 13. To limit the slope of leading half clutch (disc) in the driven half clutch abutment has been provided 14.

Installing of driven half clutch on the shaft by means of a spherical bearing 3 in conjunction with hinged connection of the leading half clutch with the shaft allows to compensate the deviation angles of the driven element in a wide range.

In general, the load with torque on the finger with the rolled ball is equal to

$$T = P_k l, \quad (1)$$

where P_k – is circular force, N;

l – distance from the central axis of the clutch to the contact point of ball of the finger with the driving disk, m.

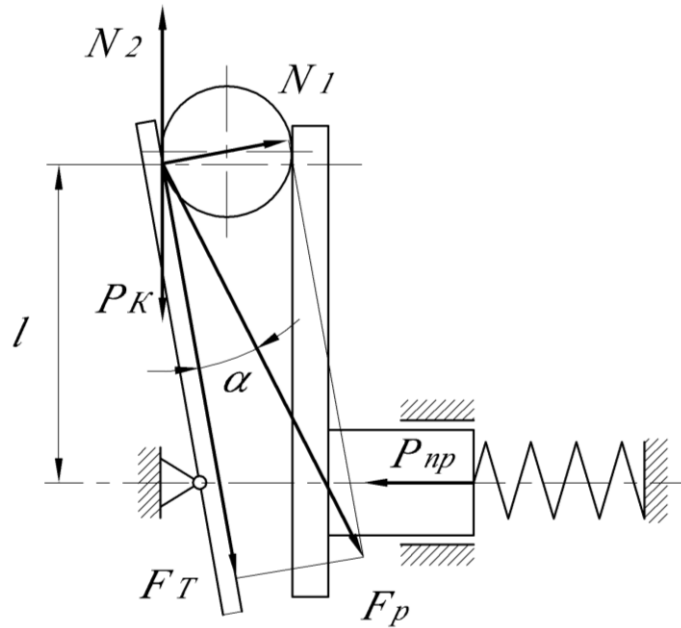

Figure 2. Calculated scheme to determine the design parameters of the contacting elements of the clutch elements and acting on them forces

The force of pressure of the spring can be represented by the formula [2]

$$P_{np} = C(\Delta'_o + \Delta_n), \tag{2}$$

where C – spring stiffness;

Δ'_o – previous deformation (under pressure) of the spring;

Δ_n – the current strain of the spring.

According to the design scheme the resulting force F_p , that counteracts the force of the spring P_{np} , can be expressed through normal forces N_1 and N_2 , resulting in the place of contact of the ball with the driving disc

$$P_{np} = N_1 \sin \alpha + N_2 \sin \alpha = \sin \alpha (N_1 + N_2). \tag{3}$$

According to calculating scheme the equilibrium condition of forces at which the transmission of torque is as follows

$$P_{np} \geq F_p + \frac{F_T}{\cos \alpha}. \tag{4}$$

The value of the friction force F_T can be expressed through normal force N_1 . Accordingly friction force is equal to [1]

$$F_T = N_1 f, \tag{5}$$

where f – is the coefficient of friction.

In view of (4) and dependence (5) the condition to ensure transmission of torque can be written as follows

$$P_{np} \geq \sin \alpha (N_1 + N_2) + \frac{N_1 f}{\cos \alpha}. \quad (6)$$

As it is evident from the design scheme normal force N_2 is oppositely directed to circular force P_κ , but it is equal to it by value.

$$N_2 = P_\kappa. \quad (7)$$

Accordingly the force of half clutches contact can be determined from the condition (6)

$$N_2 \sin \alpha \leq P_{np} - \frac{N_1 f}{\cos \alpha} - N_1 \sin \alpha;$$

$$N_2 \leq \frac{P_{np} - N_1 f \cdot 1/\cos \alpha - N_1 \sin \alpha}{\sin \alpha}, \quad (8)$$

according to equation (7) circular force is equal to

$$P_\kappa = \frac{P_{np} - N_1 f \cdot 1/\cos \alpha - N_1 \sin \alpha}{\sin \alpha}. \quad (9)$$

Considering the dependence (2), formula (9) will take the following form

$$P_\kappa = \frac{C(\Delta'_o + \Delta_n) - N_1 f \cdot 1/\cos \alpha - N_1 \sin \alpha}{\sin \alpha}. \quad (10)$$

When calculating the torque that accepts the overload clutch, taking into account the dependence (10), the estimated value of the torque can be determined by the formula

$$T = \frac{lC(\Delta'_o + \Delta_n) - N_1 f \cdot 1/\cos \alpha - N_1 \sin \alpha}{\sin \alpha}. \quad (11)$$

To establish the functional dependence of torque, that is transmitted by the clutch, from its design parameters the analytical dependence (11) has been calculated by substituting variable values:

- distance from the central axis of the clutch to the point of contact of ball of the finger with the driving disc, namely of the number $l = 0,1; 0,15; 0,2; 0,25$ m;
- spring stiffness $C = 3000, 4000, 5000, 6000, 7000$ N/m;
- current deformation of the spring $\Delta_n = 0,01; 0,015; 0,02; 0,025$ m;
- coefficient of friction $f = 0,1; 0,15; 0,2$;
- inclination angle of the driving disc $\alpha = 3, 5, 7, 9, 11, 13, 15^\circ$.

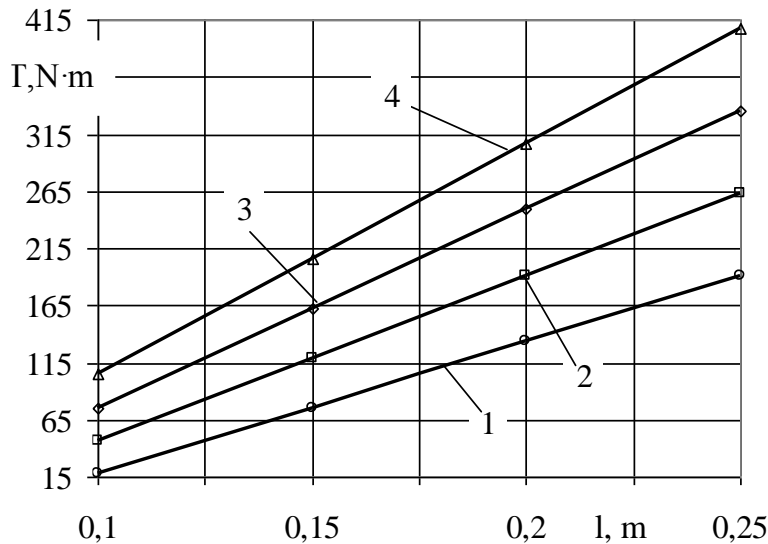

Figure 3. Dependence of change of torque on the size of the distance from the central axis of the clutch to the point of contact of ball of the finger with the driving disc with the changing values of current deformation of the spring: 1 – $\Delta_n = 0,010$ m; 2 – $\Delta_n = 0,015$ m; 3 – $\Delta_n = 0,020$ m; 4 – $\Delta_n = 0,025$ m

By analyzing numerical data obtained by calculating the dependence (11), and also graphic dependencies $T = f(l)$ (Fig. 3) it has been proved that this dependence is linear. It is obvious that the increase of shoulder applying of circular force causes the increase of torque. Increasing of the current deformation of the spring is directly connected with the increase of load capacity of the clutch. Thus, according to the same values of diameter of the driving disc (which is directly related to the value of l), there is a corresponding increase of the load capacity of the device depending on the magnitude of the distance from the central axis of the clutch to the point of contact of ball of the finger with the driving disc. In accordance with the values $\Delta_n = 0,010$ m, at the step of current deformation of the spring 0,005 m – in 5,7 times; at $\Delta_n = 0,015$ m – in 2,7 times; at $\Delta_n = 0,020$ m – in 2,3 times and at $\Delta_n = 0,025$ m – in 2,1 times.

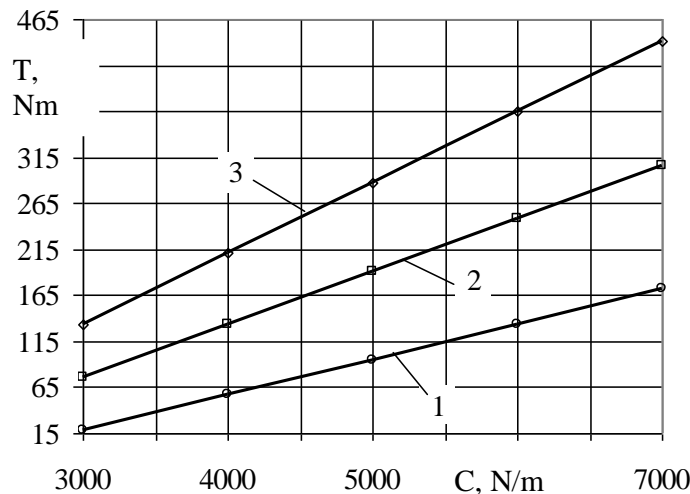

Figure 4. Dependence of the change of torque from the stiffness of spring at different values of the magnitude of the distance from the central axis of the clutch to the point of contact of ball of the finger with the driving disc: 1 – $l = 0,10$ m; 2 – $l = 0,15$ m; 3 – $l = 0,20$ m

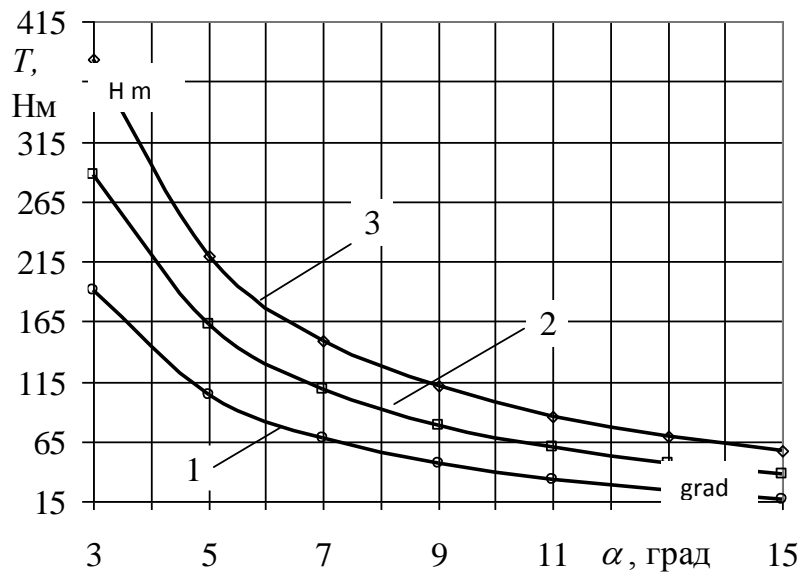

Figure 5. Dependence of the change of torque from the inclination of angle of the driving disc at different values of the magnitude of the distance from the central axis of the clutch to the point of contact of ball of the finger with the driving disk: 1 – $l = 0,15$ m; 2 – $l = 0,20$ m; 3 – $l = 0,25$ m

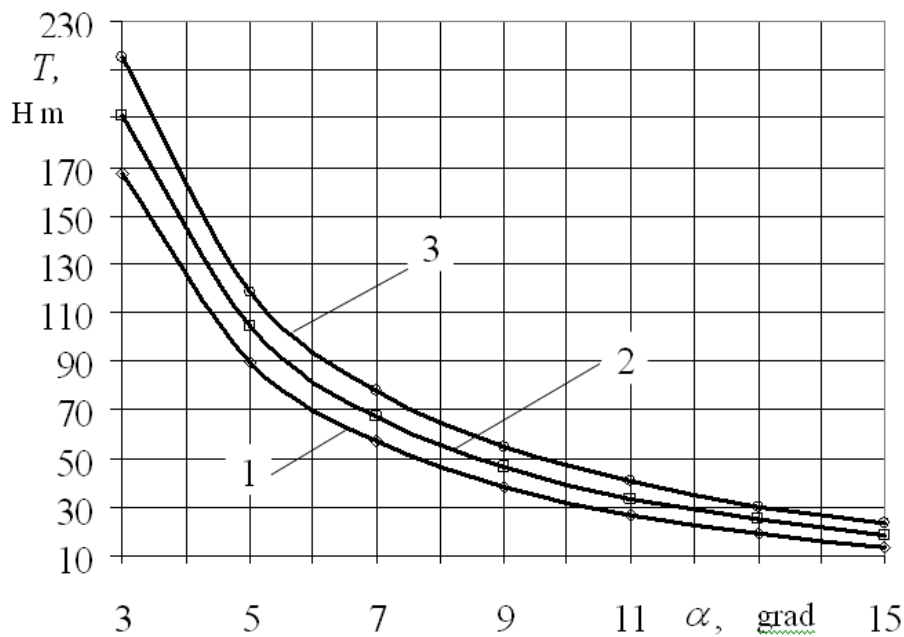

Figure 6. Dependence of the change of torque from the inclination angle of the driving disc at different values by changing the values of the coefficient of friction: 1 – $f = 0,2$; 2 – $f = 0,15$; 3 – $f = 0,1$

Analyzing the obtained results, we can say that the load capacity of the device is higher at lower values of the inclination angle of the driving disc. This is because the increase of the torque occurs to a vertical position of the driving disc, i.e. at $\alpha = 0^\circ$ – clutch goes into a safety mode. In addition, the load capacity of the device is influenced by the coefficient of friction between the contacting surfaces. For example, at $f = 0,2$ the value of torque is 1.28 times lower than at $f = 0,1$ – this is due to friction losses. Accordingly, the actual function is to supply oil to the contact zone of rolled balls with the driving disk. This technological solution will

significantly reduce losses on the friction of contacting surfaces.

Obtained theoretical dependences allow to evaluate comprehensively the intensity of the impact of a parameter (at given others), on the value of torque perceived by the developed overload clutch and may be the basis for the development of engineering design techniques of the similar devices.

Conclusions.

1. The design of the hydraulic overload clutch with hypersensitivity has been developed, which is protected by patent for utility model.

2. Theoretical conditions for design of the overload clutch have been developed, analytical dependencies for determining the value of torque have been obtained, and dependencies of the change of the value of the torque on the design and force parameters have been established.

References

1. Polyakov V.S., Barabash I.D., Ryahovs'kij O.A. Spravochnik po muftah, L.: Mashinostroenie, 1974, 352 p. [In Russian].
2. Ryahovs'kij O.A., Ivanov S.S. Spravochnik po muftam, L.: Politehnika, 1991, 384 p. [In Russian].
3. Tepinkechiev V.K. Predohranitel'nye ustrojstva ot peregruzov stankov, M.: Mashinostroenie, 1969, 157 p. [In Russian].
4. Malashchenko V.O. Mufti privodiv. Konstrukciya ta prikladi rozrahunku, L'viv. nac. u-t, „L'vivs'ka politehnika“, 2006, 196 p. [In Ukrainian].
5. Pavlishche V.T. Osnovi konstruyuvannya ta rozrahunok detalej mashin, K.: Vishcha shkola, 1993, 556 p. [In Ukrainian].
6. Nagornyak S.G., Luciv I.V. Predohranitel'nye mekhanizmy metalloobrabatyvayushchego oborudovaniya, K.: Tekhnika, 1992, 70 p. [In Russian].
7. Naukovo-prikladni osnovi stvorennya gvintovih transportno-tehnologichnih mekhanizmiv Rogatins'kij R.M., Gevko B.M., Dyachun A.C., Monografiya, Ternopil', 2014, 278 p. [In Ukrainian].
8. Gevko B.M., Rogatins'kij R.M. Vintovye mekhanizmy sel'skohozyajstvennyh mashin, L'vov, 1989, 176 p. [In Russian].
9. Flik E.H.P. Mekhanicheskie privody sel'skohozyajstvennyh mashin, M., 1984, 185 p. [In Russian].
10. Pidvishchennya tekhnichnogo rivnya gnuchkih gvintovih konveeriv. Gevko R.B., Vitrovij A.O., Pik A.I. Monografiya, Ternopil', 2012, 204 p. [In Ukrainian].
11. Gevko B.M., Marchuk R.M. ta inshi. Mufta zapobizhna, Patent no. 108267, Byul. no. 13, 2016.

Список використаної літератури

1. Поляков, В.С. Справочник по муфтах [Текст] / В.С. Поляков, И.Д. Барабаш, О.А. Ряховский. – Л.: Машиностроение, 1974. – 352 с.
2. Ряховский, О.А. Справочник по муфтам [Текст] / О.А. Ряховский, С.С. Иванов. – Л.: Политехника, 1991. – 384 с.
3. Тепинкечиев, В.К. Предохранительные устройства от перегрузов станков [Текст] / В.К. Тепинкечиев. – М.: Машиностроение, 1969. – 157 с.
4. Малащенко, В.О. Муфти приводів. Конструкція та приклади розрахунку [Текст] / В.О. Малащенко. – Л.: Львівський національний університет „Львівська політехніка“, 2006. – 196 с.
5. Павлище, В.Т. Основи конструювання та розрахунок деталей машин [Текст] / В.Т. Павлище. – К.: Вища школа, 1993. – 556 с.
6. Нагорняк, С.Г. Предохранительные механизмы металлообрабатывающего оборудования [Текст] / С.Г. Нагорняк, И.В. Луців. – К.: Техніка, 1992. – 70 с.
7. Науково-прикладні основи створення гвинтових транспортно-технологічних механізмів [Текст] / Р.М. Рогатинський, І.Б. Гевко, А.С. Дячун. – Тернопіль: ТНТУ імені Івана Пулюя, 2014. – 278 с.
8. Гевко, Б.М. Винтовые механизмы сельскохозяйственных машин [Текст] / Б.М. Гевко, Р.М. Рогатинський. – Львов, 1989. – 176 с.

9. Флик, Э.П. Механические приводы сельскохозяйственных машин [Текст] / Э.П. Флик. – М.:1984. – 185 с.
10. Підвищення технічного рівня гнучких гвинтових конвеєрів: монографія [Текст] / Р.Б. Гевко, А.О. Вітровий, А.І. Пік. – Тернопіль: Астон, 2012. – 204 с.
11. Патент №108267 Муфта запобіжна [Текст] / Гевко Б.М., Марчук Р.М. та інші. Бюл. №13, 2016.

УДК 621.86

ОБГРУНТУВАННЯ ПАРАМЕТРІВ ГІДРАВЛІЧНОЇ ЗАПОБІЖНОЇ МУФТИ

**Роман Марчук¹; Роман Комар¹; Тарас Дубиняк¹;
Олег Фльонц²; Володимир Диня²; Іван Семенів²**

*¹Тернопільський національний технічний університет імені Івана Пулюя,
Тернопіль, Україна*

*²ВП НУБіП України «Бережанський агротехнічний інститут»,
Бережани, Україна*

Резюме. Створення нових типів машин і механізмів транспортно-технологічних систем і їх приводів сприяє подальшому розвитку народного господарства та розширенню їх номенклатури, підвищенню продуктивності праці за рахунок упровадження досягнень науково-технічного прогресу.

Наведено нову конструкцію гідравлічної запобіжної муфти підвищеної чутливості, виведено аналітичні залежності для визначення розрахункового крутного моменту залежно від силових і конструктивних параметрів.

Ключові слова: гідравлічна запобіжна муфта, крутний момент.

Отримано 05.04.2017