



MANUFACTURING ENGINEERING AND AUTOMATED PROCESSES

МАШИНОБУДУВАННЯ, АВТОМАТИЗАЦІЯ ВИРОБНИЦТВА ТА ПРОЦЕСИ МЕХАНІЧНОЇ ОБРОБКИ

UDC 621.923

MODULAR 3D MODELING OF ENDS BILATERAL GRINDING PROCESS BY WHEELS WITH CONICAL CALIBRATING SECTIONS

**Vitalii Kalchenko; Volodymyr Kalchenko;
Olena Slednikova; Dmytro Kalchenko**

Chernihiv National University of Technology, Chernihiv, Ukraine

Summary. *The modular 3D model of the process of grinding the ends of circular rotating parts during processing and oriented noncircular grinding wheels with conical sections templating. On the basis of which created new ways of processing the ends of details that provide a combination of the first end surface of the treated parts from forming a conical sizing section along the line eliminates geometrical errors of morphogenesis. For grinding wheels used combined correction, which consists of the end surface changes, performing roughing and tapered gauge performing finish grinding.*

Key words: *grinding the ends of parts, oriented grinding wheels, conical calibrating areas, editing tools.*

Received 01.12.2016

Urgency of the research. In engineering plants are widely used, such details as piston pins, bushings, rod, end extent multifaceted uncarved plate to which side surfaces are required providing high accuracy and efficiency of processing. Modular 3D models shaping the ends of these parts to the processing machines and bilateral side grinding are based on studies of models of new high-performance grinding methods ensure high accuracy and performance of the treated surfaces.

Analysis of recent research and publications. In works [1, 2] developed a modular mechanical 3D modeling side grinding of a detail with oriented tool and the influence of the grinding wheel is studied, its orientation and geometric details on the error surface finish. With the increase in the radius of the grinding wheel, decrease the angle of its orientation relative to parts a greater party details along the feeding direction error are reduced. In bilateral side grinding, due to simultaneous processing of two ends, large diameter grinding wheels got more accurate end surfaces and processing performance.

The famous company Saturn (Germany) takes the processing of various parts for machines with bilateral side grinding circular supply of parts 1, mounted in the drum feeding products 2, the processing area (Fig. 1) [3]. Processing is performed end surface grinding wheels 3, 4, geometric error of this depends on the orientation angles and diameters of grinding wheels. In this scheme of processing accuracy is achieved by finishing pass, the angle and diameter grinding wheel is determined from the condition of precision machined end surfaces

of parts. If the allowance for processing is more than acceptable, with fair treatment, the grinding is performed with few passes, which reduces processing performance. The maximum diameter of tools at the entrance to the processing area performs rough grinding end surfaces of parts, and the output – finishing, which reduces the precision machined surfaces due to its wear parts. Correction of grinding wheels is done only at the side surfaces perpendicular to their axes.

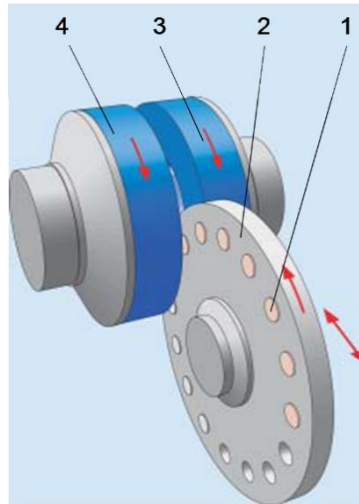

Figure 1. Bilateral end side grinding with circular supply details of the processing area

In the patent [4], to improve the accuracy of treatment, first was proposed to use grinding wheels calibrated areas. New way of editing was investigated in [4-9], but editing calibrated areas of grinding wheels is a pencil with a point contact, profile of calibrated areas are in a curve of the fourth order, which increases the error handling. In [9] grinding wheel is working with calibrated concave portion, thus forming of a side surface of a details is the largest and smallest diameters, which increases uncertainty formation. Fig. 2 shows the profile of the grinding wheel 1 and its bias 2. As shown in Fig. 2 maximum and minimum diameters wear out, and the end surface precision part 3, which nominal length l , decreases.

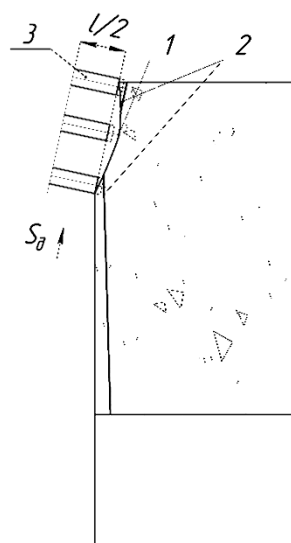

Figure 2. The profiles of grinding wheels

Purpose of the research. Developing of modular 3D models of formation and based on

their research of new methods of polishing the sides of round noncircular details.

Target setting. In well known methods of bilateral mechanical grinding of details, where wheels are guided for removal allowance of side surface grinding wheels, there is always a geometric error, it depends on the diameters and angles of orientation tools. In this work, formation is happening according to the method of copying with the circles with conical calibrating areas, rectilinear generatrix which is at the front plane of the work pieces. To analyze the need to develop modular 3D models of mechanical grinding process oriented bilateral instruments with conical calibrating areas, based on the research which will create new highly effective methods of treatment. To increase the accuracy of the processed side surfaces of parts to be developed editing conical sections calibrating grinding wheels with straight generators on the machine that will run 3342ADO end surface of the diamond ruling tool.

Description of module 3D models and new ways of grinding of round parts, rotating and noncircular oriented. The scheme of bilateral mechanical polishing is shown in Fig. 3. Processing is focused grinding wheels 3, 4, mounted on wheel head 1, 2 and turns which the relatively spherical joints 10. Grinding wheels are oriented in two directions: vertical (angle ψ) and horizontal (angle φ). First the overall orientation angle of grinding wheels is calculated, whose value depends on the allowance that was withdrawn. Of the total value of the angle calculated angles ψ and φ , the ratio between them is elected on the condition of combining parts of the plane face straight generatrix calibrating conical section of the grinding wheel during morphogenesis. About-face is in a plane that passes through generating conical calibrating area and coincides with the axis of the grinding wheel.

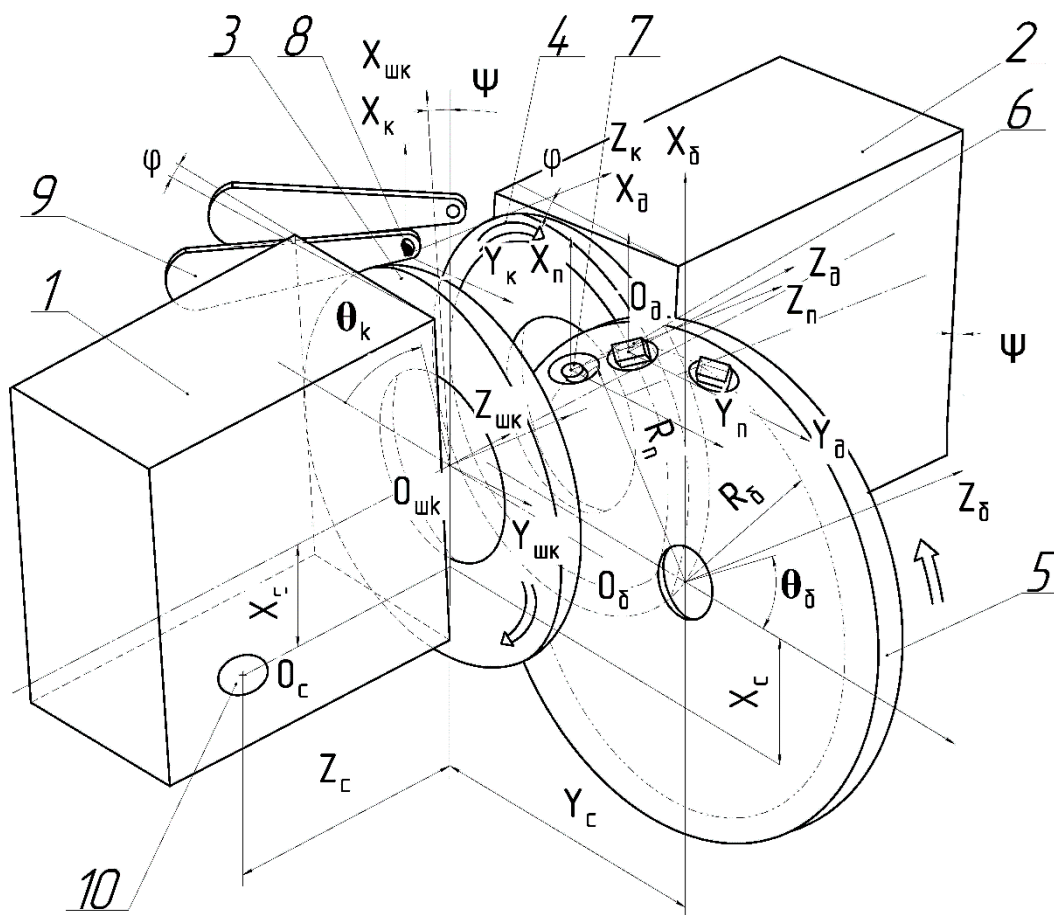

Figure 3. Model of cylindrical parts with noncircular profile processing

Before processing grinding wheels get corrected. Areas for removing rough allowance

getting corrected with unit 9, which attached with diamond pencil 8 that came with the machine, and calibrating areas of grinding wheels – ruling diamond tool 7 with a circular flat side, which is enshrined in the drum feed products area which should be tangent to straight of calibrating generatrix conical section of the grinding wheel in tetanus. Plane end moves in an arc and a circle of radius R_{Π} is tangent to the straight generatrix of calibrating areas of the grinding wheel. While correcting, diamond dressers are put at the size of the length of the parts, and to compensate for wear of grinding wheels to move in the axial direction. This draft rule a testis area gets corrected with a large value of supply, providing high cutting ability of the grinding wheel, and actual – with less, providing a lower roughness of processed end surfaces. This edit ensures consistency of size parts at the exit of the treatment zone areas conical wheels and improves accuracy compared to [9].

The radius-vector of circular side surface of the diamond dresser (Fig. 4) flat sided, that id described as cylindrical module:

$$\bar{r}_{pr}(\theta_n, r_j) = C_{z_n \cdot \theta_n \cdot r_j}^{IIu} \cdot \bar{e}_4, \tag{1}$$

where $C_{\theta_n \cdot z_n \cdot r_j}^{IIu}$ – cylindrical module of the diamond dresser surface; r_j, z_n, θ_n – radius, length and angle coordinate of diamond dresser surface; \bar{e}_4 – radius vector of the beginning of the coordinate system.

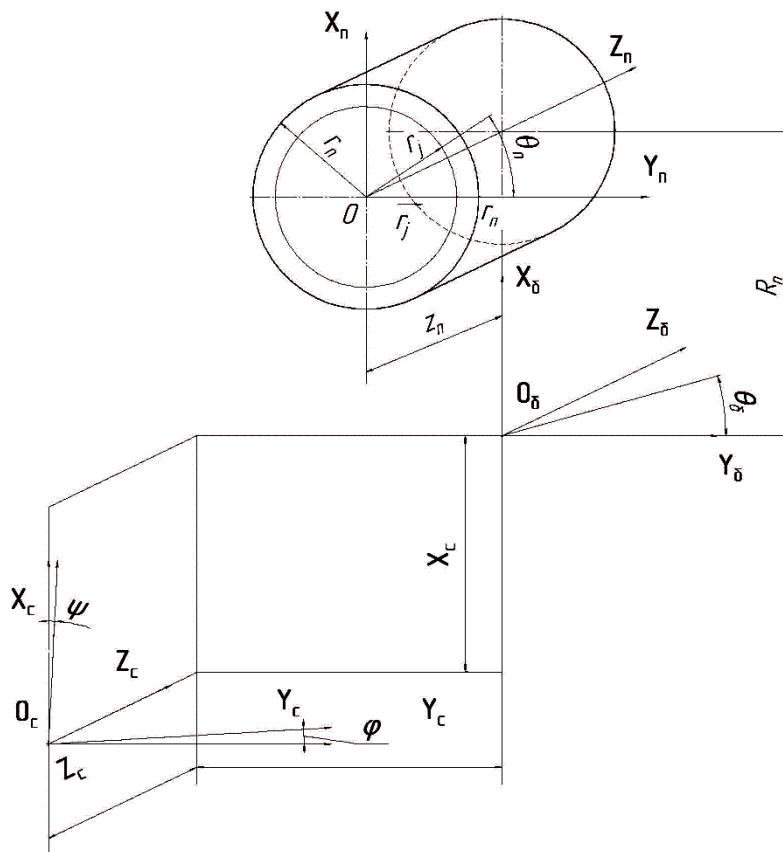

Figure 4. The diamond dresser

Let's write a cylindrical module of diamond dresser surface through single coordinate matrix of fourth order [10]

$$C_{\theta_n \cdot z_n \cdot r_j}^{Ilu}(\theta_n, r_j) = M3(-z_n) \cdot M6(\theta_n) \cdot M2(r_j), \quad (2)$$

where $M1, M2, M3, M4, M5, M6$ – Coordinate systems transformation matrix that model the progressive movement and turns around the respective axes.

Fig. 5 shows a profile 1 of grinding wheel with calibrating conical area and its demolition 2, which does not affect the accuracy of processing, because the straightforward generating while grinding cooperate with the side of the work piece 3, getting a needed detail of desired length l .

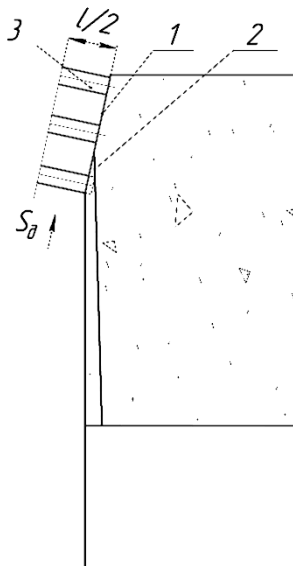

Figure 5. The profiles of grinding wheels

The radius-vector of calibrating areas of grinding while using flat sides diamond dresser

$$\bar{r}_{instr}(\theta, \theta_{\delta}, r_j) = C_{\theta}^{\Phi n} \cdot S_{X_c \cdot \varphi \cdot \psi}^{On} \cdot P_{Z_c \cdot Y_c \cdot X_c}^{In} \cdot C_{\theta_{\delta} \cdot R_n}^{Tn} \cdot \bar{r}_{pr}(\theta_n, r_j), \quad (3)$$

where $C_{\theta_{\delta} \cdot R_n}^{Tn}$ – cylindrical transportation module; $S_{X_c \cdot \varphi \cdot \psi}^{On}$ – spherical module responsible for orientation; $P_{Z_c \cdot Y_c \cdot X_c}^{In}$ – rectangular module movement; $C_{\theta}^{\Phi n}$ – cylindrical module forming surface of the tool; θ_{δ} – property of the grinding wheel surface that is responsible for the angular position of the working surface of circle; R_n – radius, where diamond pencil to drum feed is locked; X_c, Y_c, Z_c – settings that define the position of the center of a spherical finger on the drum feeding and working plane circle; φ, ψ – angles of wheelhead orientation in the horizontal and vertical planes respectively which depend on removable allowance; θ – the grinding wheel angle setting.

Cylindrical drum module

$$C_{\theta_{\delta} \cdot R_n}^{Tn}(\theta_{\delta}) = M6(-\theta_{\delta}) \cdot M1(R_n). \quad (4)$$

Rectangular plug-in transfer

$$P_{Z_c \cdot Y_c \cdot X_c}^{In} = M3(Z_c) \cdot M2(Y_c) \cdot M1(X_c). \quad (5)$$

Spherical module orientation

$$S_{\varphi\psi X_c}^{On} = M1(-X_c) \cdot M5(-\psi) \cdot M4(\varphi). \quad (6)$$

Cylindrical module forming surface of the tool

$$C_{\theta}^{\Phi n}(\theta) = M6(\theta). \quad (7)$$

System of links

$$\left. \begin{aligned} \theta_n = \theta_n(\theta_{\delta}); \quad z_n = l/2; \quad R_n = const; \quad X_c, Y_c, Z_c = const; \quad \varphi = \varphi(\delta); \quad \psi = \psi(\delta); \\ \frac{\partial \bar{r}_d(r_j, \theta, \theta_{\delta})}{\partial r_j} \times \frac{\partial \bar{r}_d(r_j, \theta, \theta_{\delta})}{\partial \theta_{\delta}} \cdot \frac{\partial \bar{r}_d(r_j, \theta, \theta_{\delta})}{\partial \theta} = 0, \end{aligned} \right\} (8)$$

where δ – allowance measurement, removable.

Nominal workpiece surface is described by equation (9) and by the system connections (14). For this radius-vector of tool surface is transferred to the coordinate system details.

The radius-vector of the workpiece is described by the equation

$$\bar{r}_d(\theta_{\phi}, \theta, \theta_{\delta}) = C_{z_{\phi}\theta_{\phi}\theta_o y_{\phi}}^{\Phi} \cdot C_{z_{\delta}\theta_{\delta} y_{\delta}}^T \cdot P_{Z_c Y_c X_c}^{\Pi} \cdot S_{\varphi\psi X_c}^O \cdot \bar{r}_{instr}(\theta, r_j), \quad (9)$$

where y_{δ}, z_{δ} – coordinates in workpiece within coordinates of feeding drum; $z_{\phi}, y_{\phi}, \theta_{\phi}$ – the length, radius and angular coordinate of the workpiece surface while formation; R_{δ} – radius, where the pieces in the drum axis feed are lockated; θ_o – angle parameter responsible for the rotation details r_j – profile coordinate of calibrating area of the grinding wheel that is specified in the axial plane of the tool.

Spherical module orientation

$$S_{\varphi\psi X_c}^O = M5(\psi) \cdot M4(-\varphi) \cdot M1(X_c). \quad (10)$$

The rectangular module transfer

$$P_{Z_c Y_c X_c}^{\Pi} = M3(-Z_c) \cdot M2(-Y_c) \cdot M1(-X_c). \quad (11)$$

Cylindrical transportation module

$$C_{\theta_{\delta} R_{\delta} y_{\delta}}^T(\theta_{\delta}) = M3(z_{\delta}) \cdot M6(\theta_{\delta}) \cdot M1(-y_{\delta}). \quad (12)$$

Cylindrical shaping module

$$C_{z_{\phi}\theta_{\phi}\theta_o y_{\phi}}^{\Phi} = M3(z_{\phi}) \cdot M6(\theta_{\phi} + \theta_o) \cdot M2(y_{\phi}), \quad (13)$$

Systems of connections

$$\left. \begin{aligned} X_c, Y_c, Z_c = const; \quad R_n = const; \quad R_{\delta} = const; \quad \varphi = \varphi(\delta); \quad \psi = \psi(\delta); \quad \theta_n = \theta_n(\theta_{\delta}); \\ z_n = l/2; \quad y_{\delta} = R_{\delta}; \quad z_{\delta} = z_{\delta}(\theta_{\delta}); \quad z_{\phi} = z_{\phi}(\theta_{\delta}); \quad \theta_{\phi} = \theta_{\phi}(\theta_{\delta}); \quad y_{\phi} = y_{\phi}(\theta_{\delta}); \quad \theta_o = \theta_o(\theta_{\delta}); \\ \frac{\partial \bar{r}_d(r_j, \theta, \theta_{\delta})}{\partial r_j} \times \frac{\partial \bar{r}_d(r_j, \theta, \theta_{\delta})}{\partial \theta_{\delta}} \cdot \frac{\partial \bar{r}_d(r_j, \theta, \theta_{\delta})}{\partial \theta} = 0. \end{aligned} \right\} (14)$$

While processing the work pieces with circular profile, which rotate θ_o on the

expression (15), while processing noncircular work pieces θ_o equals the angle of orientation drum feed products

$$\theta_o = k \cdot \theta_\phi \tag{15}$$

where k – coefficient linking the rotation of the work piece and drum parts supply products.

While producing work pieces with noncircular profile y_ϕ (13), the processing work pieces with round profile radius equal parts are built in polar coordinates.

Based on the analysis of modular 3D models, the ways of bilateral grinding of cylindrical work pieces sides with a round profile, rotating and noncircular oriented are developed.

Scheme of the processing of a work piece with a circulated profile is shown in Fig. 6, and testing processing is happening with side area of the grinding wheel. The shape building of the cylindrical work piece side 4, attached to the drum of work piece supply 3, is a method of copying. This item 4 should make at least one turnover. Fig. 6, a, b have shown initial 4^1 and final 4^2 position and point of contact details of 1 – 8 generatrix forming during calibrating area.

While processing of circulated rotating work pieces increases productivity in 1,5 – 2 times, depending on the diameter of the treated work pieces by single grinding, regardless of allowance, removing with side circle. The quality of the finished surface is improved by reducing the thermal tension of the process of the transition from the end surface where the contact area is the area of the work piece, and the calibrating area processing happens in the circulated grinding with linear contact on the generators of the cone, where the work piece 2 (Fig. 7), is fixed 1 in a drum feeding forcibly rotated via the drive roller 3 with an elastic coating of the fixation position of the axis of rotation by tension in contact roller-piece, which increases the accuracy of the base and processing.

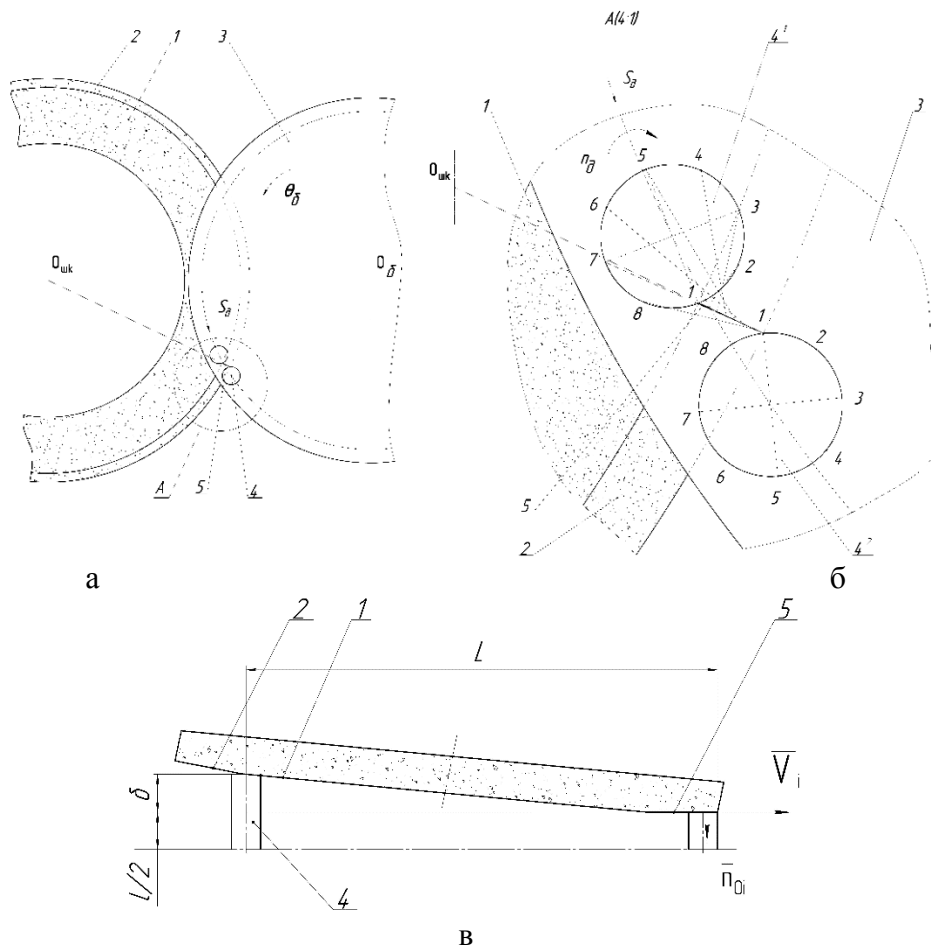

Figure 6. Scheme of sides of rods processing

Fig. 7, shows an arc of contact details turnover with the first round length L . At first the allowance for processing δ removes with section for removing the testing allowance 1. After that there is an actual grinding at the calibrating in area 2, we get the right length l of a work piece, while scalar product of vectors

$$\bar{n}_{0i} \cdot \bar{V}_i = 0, \tag{16}$$

where \bar{n}_{0i} – vector of single normal to the surface of the grinding wheel in the point-and calibrating area of the grinding wheel; \bar{V}_i – vector of velocity and relative motion of “i” point of the wheel in coordinate system of a work piece.

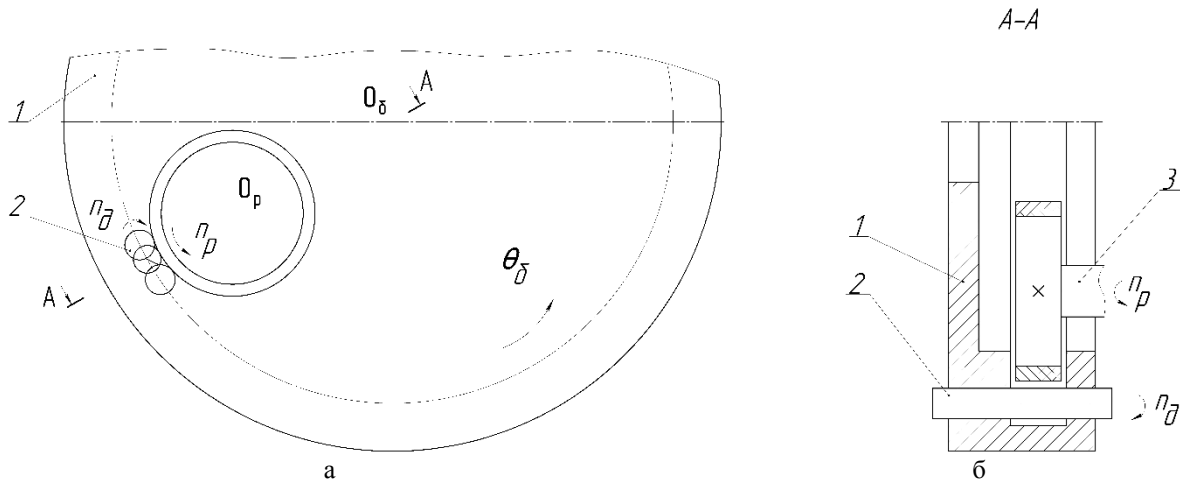

Figure 7. The drum of work piece supply

While processing the final measures 4 (Fig. 8) and other work pieces with noncircular profile, they are oriented in the drum of work piece supply 3. Details are put the way, so the projection of minimal length of a work piece and the square, passing through the axis of rotation of the rotation of the work piece and the drum center are parallel. At first the testing processing with the side of the grinding wheel 2 then the work piece 4, which is fixed into the drum of work piece supply 3 moves relatively to calibrating areas forming the method of copying, which generating conical section 5 of calibrating coincides with the width of the final measure. Fig. 8 b shows a detail during processing: 41 – details at the entrance to the processing area, 42 – in processing, 43 – out details of calibrating area. While shaping the calibrating generating conical section of the grinding wheel is tangent to the side of the work piece.

While processing the final measures 4 (Fig. 8) and other work pieces with noncircular profile, they are oriented in the drum of work piece supply 3. Details are put the way, so the projection of minimal length of a work piece and the square, passing through the axis of rotation of the rotation of the work piece and the drum center are parallel. At first the testing processing with the side of the grinding wheel 2 then the work piece 4, which is fixed into the drum of work piece supply 3 moves relatively to calibrating areas forming the method of copying, which generating conical section 5 of calibrating coincides with the width of the final measure. Fig. 8 b shows a detail during processing: 41 – details at the entrance to the processing area, 42 – in processing, 43 – out details of calibrating area. While shaping the calibrating generating conical section of the grinding wheel is tangent to the side of the work piece.

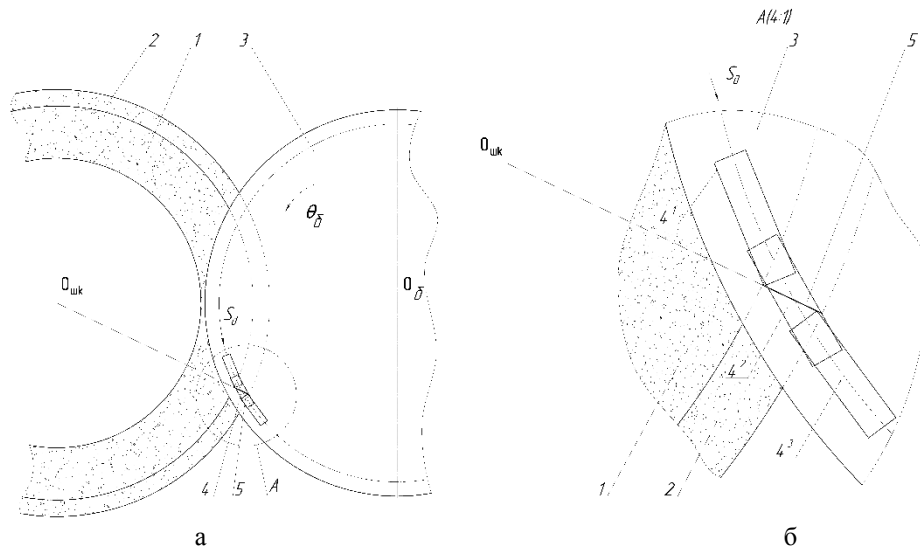

Figure 8. Scheme of machining processing the sides of ultimate measures

While processing the work pieces with noncircular profile, the maximum geometric allowance error occurs when the work pieces of the maximum diameter of the end surface of the circle, which is trimmed straight generatrix cone by copying later, thus forming a geometric error of a shape building is zero. The quality of finished surface improves by reducing the thermal tension of the process of the transition of the side surface where the contact area is the area of the work piece, and the calibrating area processing happens in flat grinding the periphery of the conical surface of the contact line on the generators of the cone. Productivity increases in 1,4 – 1,8 times, depending on size work piece, Single Pass by grinding.

Based on the created 3D models the programs calculating precision of forming side surfaces of the well known [4 – 9] and in new ways are developing. While processing by the known method, geometric shaping error is shown in Fig. 9, line 1, the processing of the new method – the line 2. As you can see from the figure, geometric error of shape building by the new way equal zero.

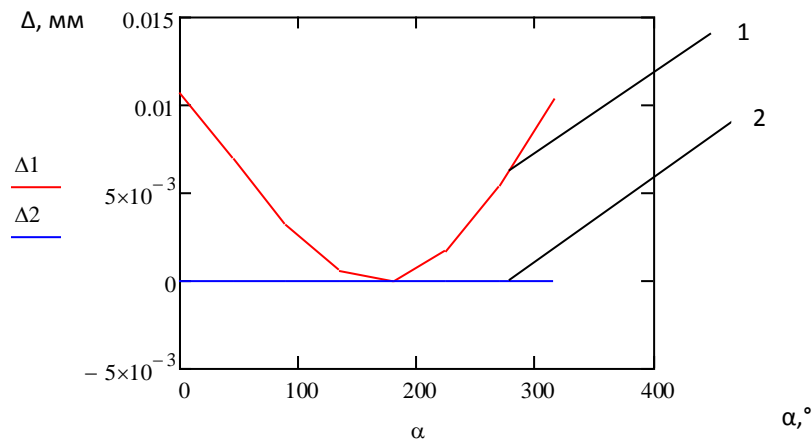

Figure 9. Geometric error of shape building

Conclusions. Developed modular 3D models of the bilateral process of of work pieces grinding with a circular and noncircular profile and focused on grinding wheels with conical calibrating areas. Based on analysis of which created new ways of grinding the first time at rotary processing circuit, eliminate geometric error of forming, by providing overlapping end surface of the treated parts with rectilinear generatrix of calibrating conical section of the grinding wheel. The roughness of the processed surface is reduced by 1 – 2 classes at the

expense of smaller areas calibrating area, obtained in correction. A method of correcting the conic calibrating areas of the grinding wheels with circular diamond dresser is proposed.

While processing round parts rotating increases productivity in 1,5 – 2 times, depending on the diameter of the processed work pieces by single grinding, regardless of allowance, taken butt circle. The quality of the finished surface is improved by reducing the thermal tension of the process of the transition from the side surface where the contact area is the area of the work piece, and the calibrating area, in the circular grinding processing happens with linear contact on the generators of the cone, where the piece rotates drive roller with an elastic surface with fixing position of the axis of rotation by tension in contact roller-piece, which increases the accuracy of the home and decoration.

While processing the work pieces with noncircular geometric profile, maximum output error occurs when the work pieces is out the maximum diameter of the end surface of the circle, which is then trimmed straight generatrix cone by copying, thus forming a geometric error equal zero. The quality of finished surface is improved by reducing the thermal tensions of the process of the transition from the side surface, where the contact area is the area of the work piece, and the calibrating area processing happens in flat grinding with the periphery of the conical surface of the contact line on the generators of the cone. Productivity increases in 1.4 – 1.8 times, depending on size of a work piece, on to account of single grinding.

References

1. Kalchenko V.I. 3D-modeliuvannia instrumentiv ta formoutvorennia pry shlifuvanni tortsiv neperetochuvanykh priamokutnykh plastyn oriietovanykh kruhom, Kalchenko V.I., Sliednikova O.S., Kalchenko D.V., Muzychka D.H., Visnyk Chernihivskoho derzhavnoho tekhnolohichnoho universytetu. Seriiia «Tekhnichni nauky»: zb. Chernihiv: ChNTU, 2014, no. 2 (73), pp. 55 – 62.
2. Pat. 99832 Ukrayina na vynakhid (korysnu model'), MPK V24V 5/00. Sposib shlifuvannia tortsiv pryamokutnykh neperetochuvanykh plastyn oriyetovanykh kruhom, Kal'chenko V.I., Muzychka D.H., Kal'chenko D.V., Sliyednikova O.S.; zayavnyk ta patentovlasnyk Chernihivs'kyi natsional'nyy tekhnolohichnyy universytet. No u201500017; zayavl. 05.01.15; opubl. 25.06. 15, Byul. No. 12. [in Ukrainian].
3. Saturn. Torcevoe shlifovanie sparennymi shlifoval'nymi krugami: Zhurnal dlja klientov firmy «Junkermaschinen», ErwinJunker: Maschinenfabric GmbH, Junkerstraße 2. Postfach 25. D 77787. Nordrash, Germany, 2005, 8 p. [in Russian].
4. Deklaratsiynyy patent 10636 Ukrayina na vynakhid (korysnu model'), MPK V24V5/04. Sposib odnochasnoho shlifuvannia dvokh tortsiv tsylindrychnykh detaley, Kal'chenko V.V., Zhadan O.V.; zayavnyk ta patentovlasnyk Kal'chenko V.V., Zhadan O.V., no u200505125; zayavl. 30.05.05; opubl. 15.11.05, Byul. No. 11. [in Ukrainian].
5. Grabchenko A.I. Shlifovanie so skreshhivajushhimisja osjami instrumenta i detali. Izdanie 2-e, dopolnennoe. (Monografija), Grabchenko A.I. Kal'chenko V.I., Kal'chenko V.V. Chernigov: ChNTU, 2015, 504 p. [in Russian].
6. Kal'chenko V.V. Profilirovanie orientirovannykh krugov pri dvustoronnem shlifovanii torcov cilindricheskikh detalej, V.V. Kal'chenko, G.V. Pasov, Informacionnye tehnologii: nauka, tehnika, tehnologija, obrazovanie, zdorov'e. Sbornik nauchnykh trudov Har'kovskogo gosudarstvennogo politehnicheskogo universiteta. Har'kov, 1999, no. 7, Chast' 2, pp. 131 – 33. [in Russian].
7. Kalchenko V.V. Profiliuvannia oriietovanykh shlifovalnykh kruhiv, V.V. Kalchenko, Visnyk ChDTU. Chernihiv, 1997, no. 3, pp. 14 – 24. [in Ukrainian].
8. Kalchenko V.I. Profiliuvannia ta znos oriietovanoho kruha pry shlifuvanni tortsiv Itali, shcho ne obertaietsia pid chas obrobky, V.I. Kalchenko, V.V. Kalchenko, Visnyk Chernihivskoho derzhavnoho tekhnolohichnoho universytetu : zb. Chernihiv : ChDTU, 2000, no. 10, pp. 5 – 13. [in Ukrainian].
9. Venzheha V.I. Pidvyshchennia efektyvnosti shlifuvannia tortsiv pry skreshchenykh osiakh detali ta kruha z kalibruvalnoiu diliankoiu : avtoref. dys. na zdobuttia nauk. stupenia kand. tekhn. nauk : spets. 05.03.01 "Protsesty mekhanichnoi obrobky, verstaty ta instrumenty", V.I. Venzheha. Kharkiv, 2009, 17 p. [in Ukrainian].
10. Reshetov D.N. Tochnost' metallorzhushhih stankov, D.N. Reshetov, V.T. Portman. M., Mashinostroenie, 1986, 336 p.

Список використаної літератури

1. 3D-моделювання інструментів та формоутворення при шліфуванні торців непереточуваних прямокутних пластин орієнтованим кругом [Текст] / В.І. Кальченко, О.С. Следнікова, Д.В. Кальченко, Д.Г. Музичка // Вісник Чернігівського державного технологічного університету. Серія «Технічні науки»: зб. – Чернігів: ЧНТУ. – 2014. – № 2 (73). – С. 55 – 62.
2. Пат. 99832 Україна на винахід (корисну модель), МПК В24В 5/00. Спосіб шліфування торців прямокутних непереточуваних пластин орієнтованим кругом [Текст] / В.І. Кальченко, Д.Г. Музичка, Д.В. Кальченко, О.С. Следнікова; заявник та патентовласник Чернігівський національний технологічний університет. – № u201500017; заявл. 05.01.15; опубл. 25.06. 15, бюл. № 12.
3. Saturn. Торцевое шлифование спаренными шлифовальными кругами: [Журнал для клиентов фирмы «Junkermaschinen»] / ErwinJunker: Maschinenfabric Gmbh, Junkerstraße 2. Postfach 25. D 77787. – Nordrash, Germany, 2005. – 8 с.
4. Деклараційний патент 10636 Україна на винахід (корисну модель), МПК В24В5/04. Спосіб одночасного шліфування двох торців циліндричних деталей [Текст] / Кальченко, В.В., Жадан, О.В.; заявник та патентовласник Кальченко В.В., Жадан О.В. – № u200505125; заявл. 30.05.05; опубл. 15.11.05, Бюл. № 1.
5. Грабченко, А.И. Шлифование со скрещивающимися осями инструмента и детали. Издание 2-е, дополненное: монография [Текст] / А.И. Грабченко, В.И. Кальченко, В.В. Кальченко. – Чернигов: ЧНТУ, 2015. – 504 с.
6. Кальченко, В.В. Профилірованіє орієнтованих кругів при двустороннем шлифовании торцов цилиндрических деталей [Текст] / В.В. Кальченко, Г.В. Пасов // Информационные технологии: наука, техника, образование, здоровье : тезисы докл. VII Междунар. науч.-техн. конф. (15-16 мая 1999 г., Харьков). – Харьков: ХГПУ, 1999. – № 7. Часть 2. – С. 131 – 133.
7. Кальченко, В.В. Профілювання орієнтованих шліфувальних кругів [Текст] / В.В. Кальченко // Вісник ЧДТУ. – Чернігів, 1997. – № 3. – С. 14 – 24.
8. Кальченко, В.І. Профілювання та знос орієнтованого круга при шліфуванні торців деталі, що не обертається під час обробки [Текст] / В.І. Кальченко, В.В. Кальченко // Вісник Чернігівського державного технологічного університету : зб. –Чернігів : ЧДТУ, 2000. – № 10. – С. 5 – 13.
9. Венжега, В.І. Підвищення ефективності шліфування торців при схрещених осях деталі та круга з калібрувальною ділянкою : автореф. дис. ... канд. техн. наук : спец. 05.03.01 "Процеси механічної обробки, верстати та інструменти" [Текст] / В.І. Венжега. – Харків, 2009. – 17 с.
11. Решетов, Д.Н. Точность металлорежущих станков [Текст] / Д.Н. Решетов, В.Т. Портман. – М.: Машиностроение, 1986. – 336 с.

УДК 621.923

МОДУЛЬНЕ 3D МОДЕЛЮВАННЯ ПРОЦЕСУ ДВОСТОРОННЬОГО ШЛІФУВАННЯ ТОРЦІВ КРУГАМИ З КОНІЧНИМИ КАЛІБРУЮЧИМИ ДІЛЯНКАМИ

**Віталій Кальченко; Володимир Кальченко;
Олена Следнікова; Дмитро Кальченко**

Чернігівський національний технологічний університет, Чернігів, Україна

Резюме. Розроблено модульну 3D модель процесу шліфування торців круглих деталей, що обертаються під час обробки, та некруглих, що орієнтуються шліфувальними кругами з конічними калібруючими ділянками. На базі її створено нові способи обробки торців деталей, які вперше забезпечують суміщення оброблюваної торцевої поверхні деталі з твірною конічної калібруючої ділянки по прямій лінії, що виключає геометричну похибку формоутворення. Для шліфувальних кругів застосовується комбінована правка, яка складається з правки торцевої поверхні, що виконує чорнову обробку, та конічної калібруючої, що виконує чистове шліфування.

Ключові слова: шліфування торців, орієнтовані шліфувальні круги, конічні калібруючі ділянки, правка інструментів.

Отримано 01.12.2016