

# OPTIMISATION OF INDUCTOR PARAMETERS FOR UNIFORM HEATING OF DISCS ACROSS THE WIDTH OF THE HARDFACING ZONE, ALLOWING FOR SCREENING

O.M. SHABLY<sup>1</sup>, Ch.V. PULKA<sup>1</sup> and A.S. PISMENNY<sup>2</sup>

<sup>1</sup>Ivan Pulyuj Ternopil State Technical University, Ternopil, Ukraine

<sup>2</sup>The E.O. Paton Electric Welding Institute, NASU, Kyiv, Ukraine

Method of calculation and optimizing of parameters of inductor for hardfacing edges of discs of an arbitrary diameter and width of the hardfacing zone with allowance for the effect of electromagnetic and heat screening on the distribution of electromagnetic field power in the hardfacing zone width is presented.

**Key words:** induction hardfacing, steel discs, optimization of parameters, two-turn ring-type inductors, protective shields, investigations, calculation

Thin steel discs of different thickness with the edge of an even or toothed shape are used in different sectors of the national economy, including agricultural machinery. To provide self-sharpening of the edges during the disc operation, their working surface is hardfaced with erosion-resistant powder-like hard alloys PG-S1, PG-S27 or of other type at heating by HF currents [1]. In this case the size and shape of the inductor are to be determined for the respective diameters of the discs and different width of the hardfacing zone, this taking time and cost.

Study [2] describes a procedure and gives the results of theoretical and experimental investigations on optimization of the structural dimensions of two-turn ring-type inductors, used for simultaneous hardfacing of thin steel toothed discs over the entire working surface. The required width of the hardfacing zone is provided, which is greater than the tooth height (Figure 1). Developed algorithm allows determination of optimal parameters of the inductor design for arbitrary diameter of the disc and width of the deposit, proceeding from technology requirements. Work [2] presents the calculated geometrical parameters of the inductor, depending on the width of the hardfaced zone and disc radius. It is found that in a number of cases with such an arrangement of the part relative to the inductor (see Figure 1), the power of the electromagnetic field is non-uniformly distributed across the width of the hardfaced zone: the highest power is concentrated at the disc face. This leads to non-uniform melting of the hard alloy on the working edge of the disc to be hardfaced, and to overheating of the base and deposited layer of the metal on its face.

All these processes can be explained as follows. Specific power of the electromagnetic field of heat

sources in the absence of the shield is determined from the formula [2]:

$$W = \frac{\sigma \omega^2 \mu_0^2}{128 \pi^2 h} \times \left[ \Delta I_u^2 A^2 a_u^2 + \Delta I_l^2 B^2 a_l^2 + 4 h a_u^2 I_u^2 C^2 e^{-2(r_2 - r)/\Delta} \right], \quad (1)$$

where  $\sigma$ ,  $\omega$ ,  $\mu_0$  are the electric conductivity, circular frequency of current and magnetic permeability of vacuum, respectively;  $\Delta = \sqrt{2}/(\sigma \omega \mu_0)$  is the depth of current penetration into the disc metal;  $I_u$ ,  $I_l$  is the current in the upper and lower branch of the inductor, respectively;  $A^2$ ,  $B^2$ ,  $C^2$  are the coefficients (integrals of elliptical type), dependent on the induction system dimensions, the formulas for their calculation being given in [2]; the other geometrical dimensions are shown in Figure 1.

This formula was used to perform calculations, illustrating the distribution of specific power of the electromagnetic field in the zone of disc hardfacing, depending on its geometrical dimensions. Figure 2 (curves 1) shows calculation results for two cases of hardfacing with zone width of 10 and 50 mm, respectively, at disc radius  $r_2 = 105$  mm. According to the

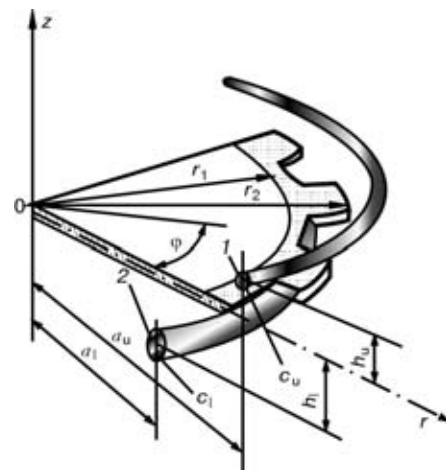
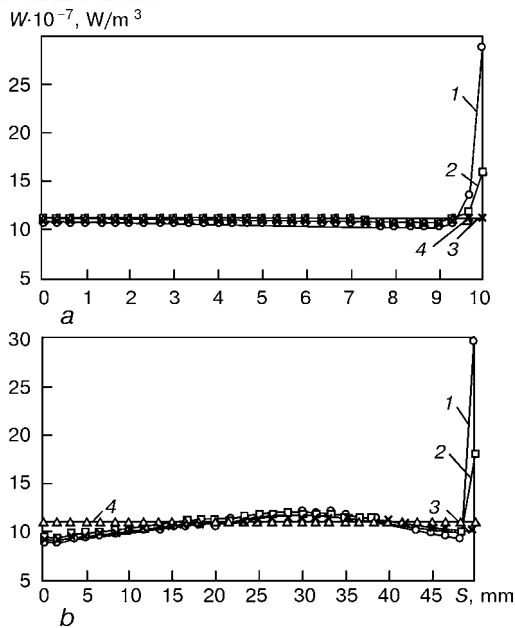

Figure 1. Fragment of the studied system (for designations see the text)

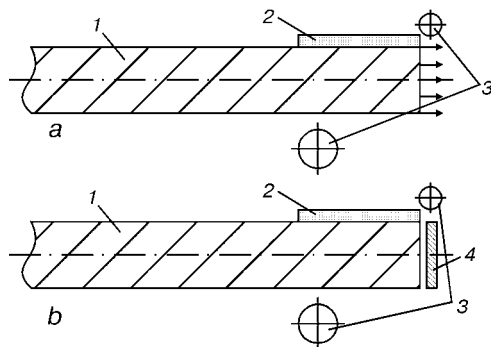

**Figure 2.** Distribution of power  $W$  of electromagnetic field of heat sources across the width of the hardfacing zone  $S$ :  $a - S = 10$  mm;  $b - S = 50$  mm at different screening of disc face; 1 -  $K = 1$  (without screening); 2 -  $K = 0.25$ ; 3 -  $K = 1$  (full screening); 4 - assigned distribution of electromagnetic field power

presented graphs, in the disc face the values of specific power of the electromagnetic field are 3 times greater than in the main part of the hardfacing zone. In practice this often leads to surface melting of the disc face.

It is known that shields of electromagnetic and thermal fields are used for redistribution and concentration of the power of electromagnetic field of heat sources in the working region of induction heating of the parts [3]. The same technique was used in this work to provide the required power distribution of the electromagnetic field of heat sources across the hardfaced zone width. In this case it was necessary to optimize the dimensions of two-turn ring-type inductor, allowing for the presence of such shields. This is precisely the subject of this study.

Figure 3 gives the schematic of a part arrangement in the inductor with a shield and without it. In the case studied by us the shield enclosed the disc being heated from the side of outer perimeter along its side (end) surface. Such a face shield drives a variable magnetic field, generated by the inductor, out of the



**Figure 3.** Disc with inductor without a shield ( $a$ ) and with a shield ( $b$ ): 1 - part; 2 - charge; 3 - ring-type inductor with two turns; 4 - shield

zone of side surface of the disc. The intensity of electromagnetic field of the heat source decreases near the disc face, and the surface to be hardfaced is exposed to a more intensive impact of the electromagnetic field. Another purpose of the shield is thermal insulation of the disc face from the environment and thus reduction of heat losses in the hardfacing zone.

Let us take the degree of screening into account, using screening coefficient  $K$ , which we will incorporate into formula (1) in determination of specific power of electromagnetic field of heat sources in the disc. In this case, the formula becomes

$$W = \frac{\sigma\omega^2\mu_0^2}{128\pi^2h} \times \left[ \Delta I_u^2 A^2 a_u^2 + \Delta I_l^2 B^2 a_l^2 + K4ha_u^2 I_u^2 C^2 e^{-2(r_2 - r)/\Delta} \right] \quad (2)$$

In formula (2) screening coefficient  $K$  varies in the range of [0; 1]. At  $K = 0$  formula (2) describes an ideal case of complete screening of the face, and at  $K = 1$  the screening effect is absent, and formula (2) will fully correspond to formula (1) from [2]. Now in reality  $K \neq 0$ , and calculation of this quantity involves certain difficulties of computational nature, as in this case it combines the electromagnetic and thermal effects. Method of calculation of the screening effect will be the subject of a separate publication. In this paper it is assumed to be equal to 0, 0.25 and 1.

Determination of inductor parameters may be performed with the required accuracy at the assigned screening coefficient, using a procedure, described in [2]. The dependence from [4]

$$W_{\text{set}} = \frac{T_{\text{set}} c \alpha \gamma m}{\text{sh}(a m \tau)} e^{a m t} \quad (3)$$

was used in calculations as the assigned mode of supplying the specific power  $W_{\text{set}}$  to a part, optimal for induction hardfacing. Here,  $T_{\text{set}}$  is the set temperature of heating of the hardfacing zone, at which sound hardfacing is ensured during time  $\tau$ ;  $c$ ,  $a$ ,  $\gamma$  are the specific heat capacity, temperature conductivity and density of disc material, respectively;  $m = \text{Bi}/2h^2$ ;  $\text{Bi} = 2h\alpha/\lambda$ ;  $2h$  is the disc thickness;  $\alpha$  is the heat removal coefficient;  $\lambda$  is heat conductivity of disc material;  $t$  is the current value of process time.

Optimisation of dimensions and determination of inductor current were performed by minimizing the following functional [2]:

$$F = \int_0^{\tau} \int_{r_1}^{r_2} (W - W_{\text{set}})^2 r dr dt, \quad (4)$$

where  $r$  is the current value of the radial co-ordinate.

Calculations demonstrated that the highest uniformity of distribution of electromagnetic field power across the width of the hardfacing zone is achieved in the ideal case at complete screening of the disc face. Deviation from the specified power of the elec-

Dependence of geometrical dimensions of induction system on screening coefficient  $K$  and disc radius  $r_2$ 

$K$	$r_2, mm$	$S, mm$									
		50					10				
		$a_u, mm$	$a_l, mm$	$h_u, mm$	$h_l, mm$	$I, A$	$a_u, mm$	$a_l, mm$	$h_u, mm$	$h_l, mm$	$I, A$
0	105	115	89	1	18.5	23.50	115	100	0	14.5	20.82
0	125	135	107	1	14.5	21.90	135	120	0	14.5	20.10
0	145	155	123	1	16.5	21.80	155	140	0	14.5	19.53
0	165	175	144	1	19.5	21.71	175	159	2	14.5	19.00
0	185	195	161	1	20.5	21.50	195	179	1	14.5	18.70
0	205	215	182	1	20.5	21.00	205	198	0	14.5	18.50
0	210	220	186	1	20.5	20.10	220	202	2	14.5	18.50
0.25	105	115	88	7	18.5	23.52	116	100	20	14.5	21.01
0.25	125	135	107	11	20.5	23.09	139	119	20	14.5	20.36
0.25	145	155	123	5	16.5	21.77	159	139	20	14.5	19.60
0.25	165	175	145	16	19.5	21.72	182	159	20	14.5	19.30
0.25	185	196	163	14	20.5	21.40	202	178	20	14.5	19.00
0.25	205	215	182	11	20.5	20.90	220	197	20	14.5	18.74
0.25	210	220	187	11	20.5	20.80	230	201	20	14.5	18.80

Note:  $c_u = 5 mm, c_l = 8 mm$ .

tromagnetic field is equal to 3–5 %, depending on the width of the hardfacing zone and disc radius (see Figure 2, curves 3, 4). This procedure was the basis to derive calculated dependencies of geometrical parameters  $a_u, a_l, h_u, h_l$  (see Figure 1) and inductor current  $I$ , depending on screening coefficient  $K$  and disc radius  $r_2$ . Similar to Figure 2, the width of hardfacing zone  $S$  was taken to be 10 and 50 mm (Table).

Analysis of computation results, given in the Table, shows that introduction of a shield into the technological sequence of induction hardfacing only slightly influences dimensions  $a_u, a_l, h_l$  and integral energy parameters of the induction system (which influences the values of inductor current  $I$ ). However, presence of a shield with a certain screening coefficient leads to a marked change of air gap  $h_u$  between the inductor upper branch and disc surface. This is attributable to strong electromagnetic coupling of the shield and the inductor upper branch due to their close location (Figure 3). Observed narrowing of gap  $h_u$  at decrease of screening coefficient  $K$  is necessary to ensure the required power in the disc being hardfaced.

Thus, use of electromagnetic and thermal shields allows controlling power distribution of the electromagnetic field of heat sources across the hardfacing zone width. The required law of distribution of electromagnetic field power may be derived for arbitrary dimensions of the discs and width of hardfacing zone. Its most uniform distribution across the hardfacing zone width is achieved in the ideal case at complete screening of the disc face. Described calculation procedure enables determination with the assigned accuracy of the design parameters of the inductor for arbitrary diameters of discs and width of hardfacing zone, allowing for screening effect.

1. Tkachev, V.N. (1971) *Wear and increase of service life of agricultural machinery*. Moscow: Mashinostroenie.
2. Shably, O.M., Pulka, Ch.V., Pismenny, A.S. (1997) Optimisation of design parameters of inductor for induction hardfacing of thin steel discs. *Avtomatich. Svarka*, **6**, 17–20.
3. Lozinsky, M.G. (1958) *Industrial application of induction heating*. Moscow: AN SSSR.
4. Shably, O.M., Pulka, Ch.V., Budzan, B.P. (1987) Optimisation of power inputs during induction hardfacing of thin-walled shaped discs. *Avtomatich. Svarka*, **1**, 36–39.